

Today: making X-ray tomography  
better

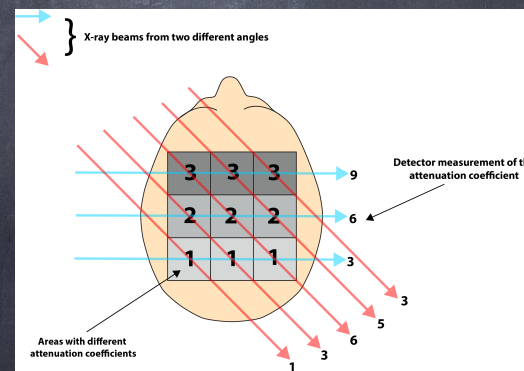
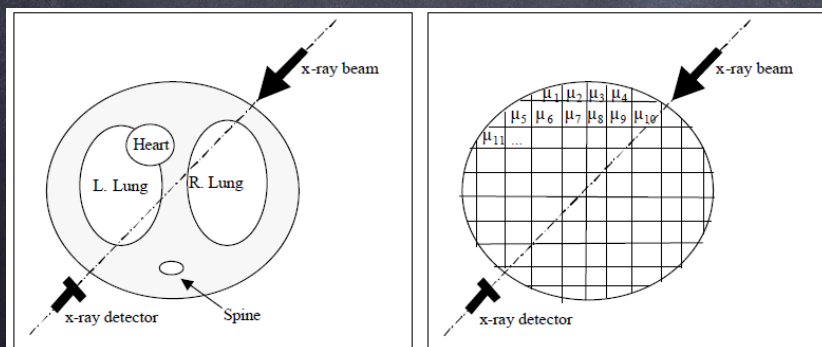
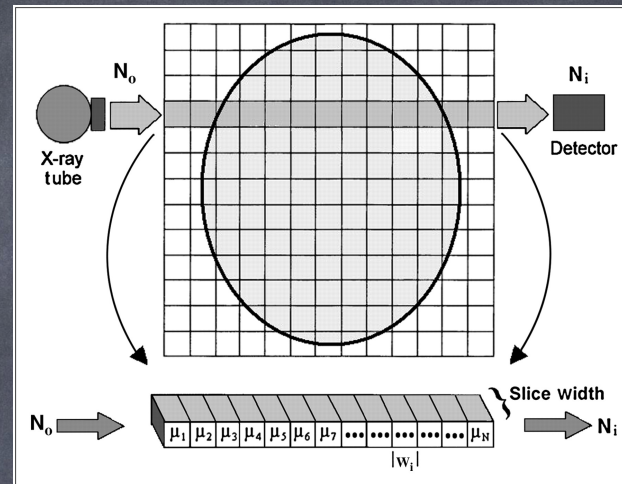
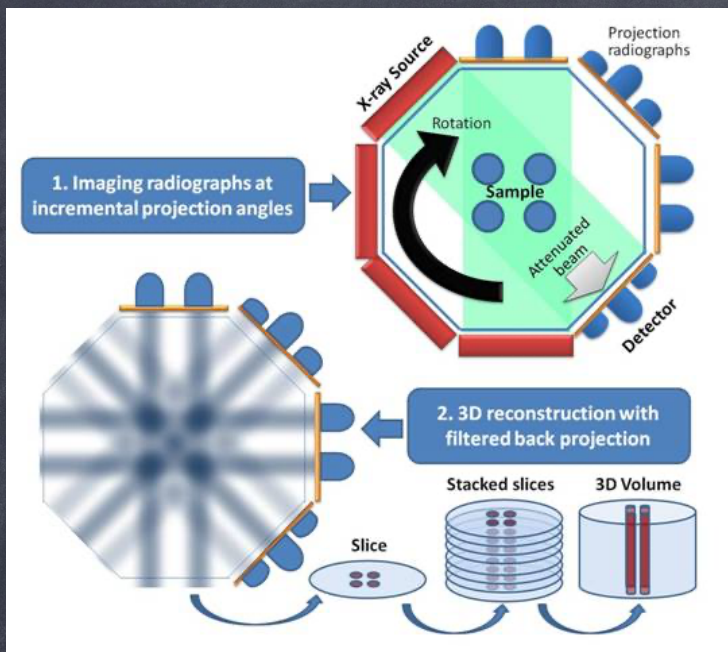
# PHY 127 FS 2025


Prof. Ben Kilminster

Lecture 10

May 9<sup>th</sup>, 2025

# Review :



CT scans with x-rays of human body  
→ best performance  voxel size  
of  $0.3 \text{ mm}^3$   
→ gantry revolves around the patient  
in 0.25 seconds  
(less than a heart beat,  
less blurring)

To get better resolution, we can use other techniques

1) smaller set-up with a smaller x-ray beam

2) x-ray focussing:

→ micro CT

micrometers ( $10^{-6} \text{ m}$ )

→ nano CT

nanometer ( $10^{-9}$ )

3) phase-contrast imaging

4) more intense x-rays beams

→ synchrotron x-rays

→ free-electron laser x-rays

(observe time  
dependence)

→ 4D

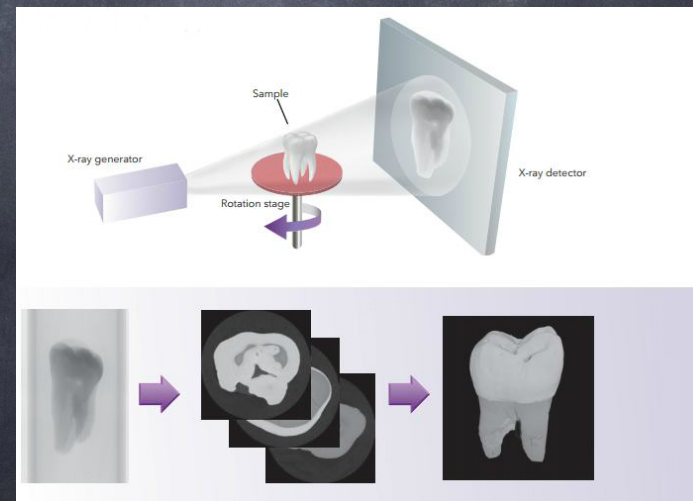


micro CT  $\mu$ CT

→ better resolution than CT scan

→ limited to sample size of  
50 cm x 50 cm x 50 cm

→ resolutions of 1  $\mu$ m  
( $1 \times 10^{-6}$  m)



Here is a practical user guide if you want to learn more.

μCT  
guide

(non-destructive)

## Laboratory x-ray micro-computed tomography: a user guideline for biological samples

[Anton du Plessis](#)<sup>1,2</sup>, [Chris Broeckhoven](#)<sup>3</sup>, [Anina Guelpa](#)<sup>1</sup> and [Stephan Gerhard le Roux](#)<sup>1</sup>

[▶ Author information](#) [▶ Article notes](#) [▶ Copyright and License information](#) [Disclaimer](#)

This article has been [cited by](#) other articles in PMC.

### Associated Data

[▶ Supplementary Materials](#)

### Abstract

[Go to: ▶](#)

Laboratory x-ray micro-computed tomography (micro-CT) is a fast-growing method in scientific research applications that allows for non-destructive imaging of morphological structures. This paper provides an easily operated “how to” guide for new potential users and describes the various steps required for successful planning of research projects that involve micro-CT. Background information on micro-CT is provided, followed by relevant setup, scanning, reconstructing, and visualization methods and considerations. Throughout the guide, a Jackson's chameleon specimen, which was scanned at different settings, is used as an interactive example. The ultimate aim of this paper is make new users familiar with the concepts and applications of micro-CT in an attempt to promote its use in future scientific studies.

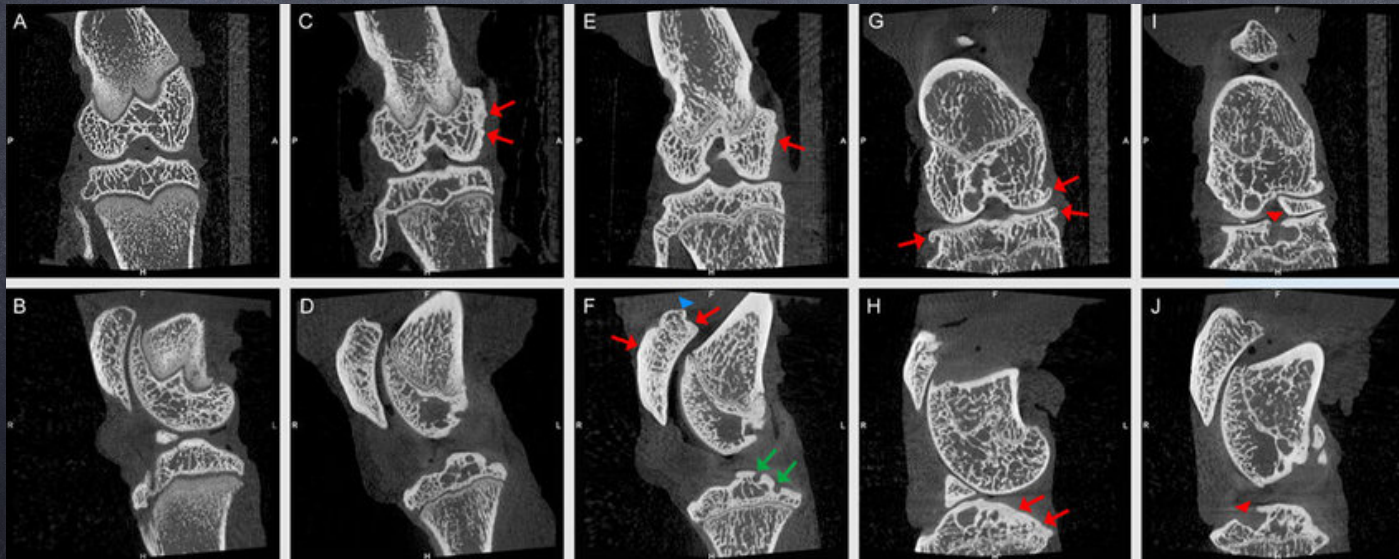
<https://www.ncbi.nlm.nih.gov/pmc/articles/PMC5449646/>

## Biological applications of micro-CT

### Related Stories

Micro-CT has been successfully applied to biological imaging in the following areas:

- In vivo imaging of head / knee
- Bone analysis
- Lung tumor detection in vivo and ex vivo
- Imaging and quantification of tumors
- Ex vivo imaging of the rabbit brain
- Phenotyping of the mouse kidney
- Imaging of mouse heart calcification and chest of live animals using contrast agents in vivo
- Imaging of tooth and jaw bone in mice



Representative photos from microCT evaluation of knee joints using the novel scoring system. (A) Dorsal and (B) sagittal reconstructions from a 2 month old Hartley guinea pig with no clinically significant OA lesions.

# Example of a commercial microCT system

## Quantum GX2 microCT Imaging System



Image beyond bone – into oncology, cardiovascular and pulmonary diseases, and much more, with the Quantum GX2 microCT imaging system. With the Quantum GX2, flexibility is key. Combining the ability to perform high speed, low dose scans, ideal for longitudinal studies, across multiple species (mice, rats, rabbits) with high resolution ex vivo scanning, the Quantum GX2 microCT imaging system offers the flexibility and performance you need to not just image, but further understand your disease models.

Part Number CLS149276

[Request More Information](#)

[Request a Quote](#)

### Overview

[Resources, Events & More](#)

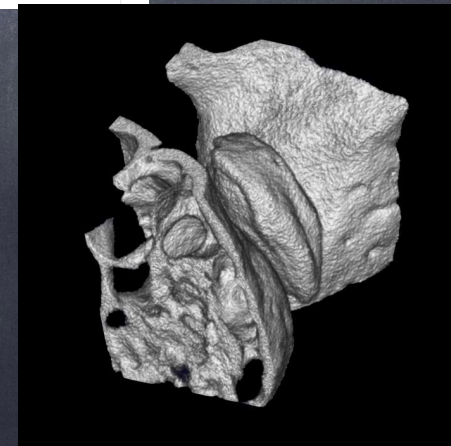
[Image Gallery](#)

The Quantum GX2 microCT scanner is a true multispecies preclinical imaging system, offering the flexibility to enable longitudinal in vivo imaging as well as ex vivo sample scanning. With a 163mm imaging bore, an entire rabbit can be placed inside the scanner for in vivo scanning, while the 18mm FOV allows for high resolution scanning of ex vivo samples. Combined with PerkinElmer's 3-dimensional optical imaging systems, and automated bone analysis software (AccuCT™), the Quantum GX2 microCT imaging system provides maximal flexibility and function. Whether your research focus is oncology, cardiovascular disease, orthopedics or pulmonary disease, the Quantum GX2 is versatile enough to deliver the results you need.

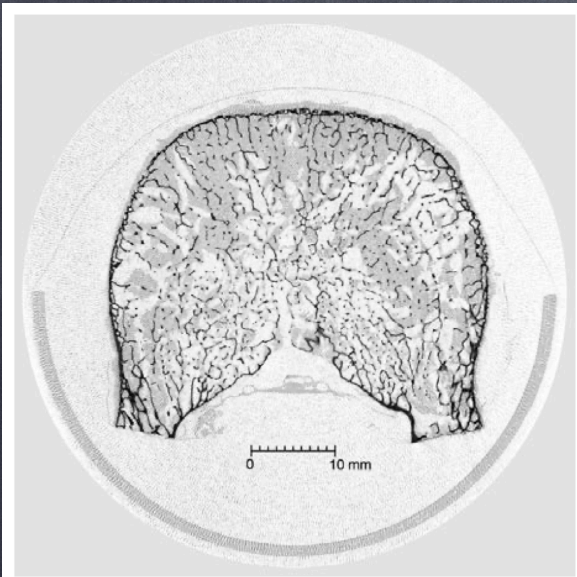
### Key Features

- High resolution (2.3 micrometer voxel size)
- High-speed (scans as fast as 3.9 seconds)
- Low-dose imaging for longitudinal in vivo studies
- Four Field Of Views (FOVs) – 18, 36, 72, and 86 mm
- Multispecies imaging capabilities (Zebrafish/mouse/rat/guinea pig/rabbit)
- Two-phase retrospective respiratory and cardiac gating
- Seamlessly co-registration of functional optical signals (from IVIS® Spectrum or FMT®) with microCT imaging data

Combine the Quantum GX2 microCT imaging with PerkinElmer's other in vivo imaging modalities (optical and PET) to gain greater insight into disease progression and treatment response non-invasively.

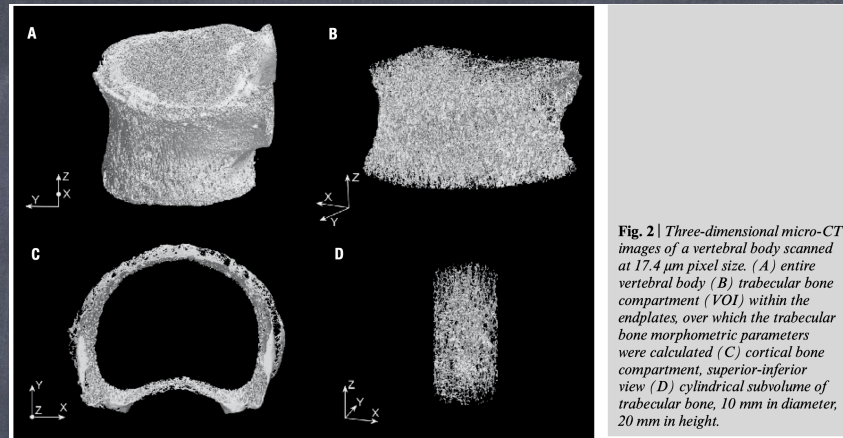


Some examples  
of  $\mu$ CT scans :

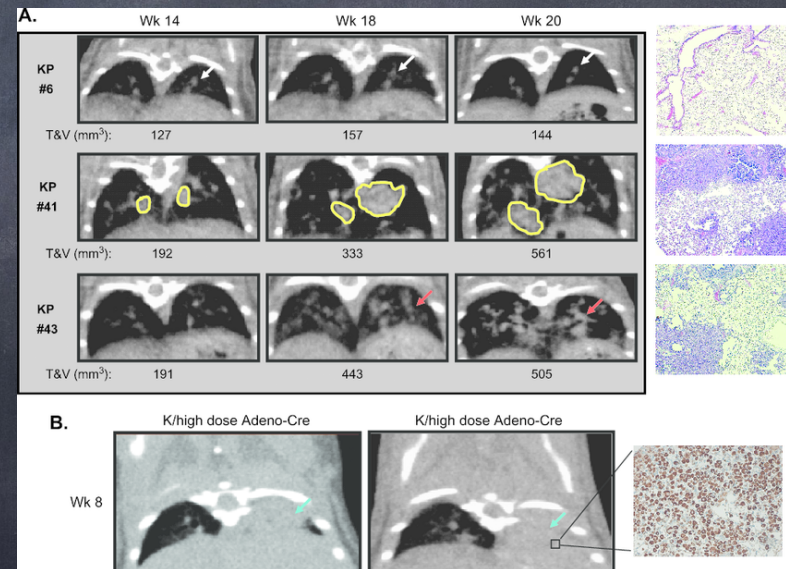


**Fig. 1** | Micro-CT cross-section image of a human vertebral body, at  $17.4 \mu\text{m}$  pixel size ( $3936 \times 3936$  pixel,  $68.5 \times 68.5$  mm).

human vertebra - spinal bone



**Fig. 2** | Three-dimensional micro-CT images of a vertebral body scanned at  $17.4 \mu\text{m}$  pixel size. (A) entire vertebral body (B) trabecular bone compartment (VOI) within the endplates, over which the trabecular bone morphometric parameters were calculated (C) cortical bone compartment, superior-inferior view (D) cylindrical subvolume of trabecular bone, 10 mm in diameter, 20 mm in height.



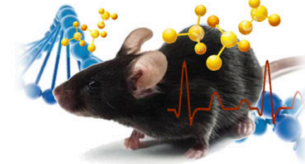
Lung tumor identification in mouse

we have one here!



University of Zurich<sup>UZH</sup>

Home



## Zurich Integrative Rodent Physiology (ZIRP)

About ZIRP • [Imaging](#) • Laboratory Analyses • Metabolism & Oxygen • Surgical Services • Telemetry • 3Rs • News • Courses Lectures

Optical Imaging

**microCT**

Body Composition Analysis

Irradiation

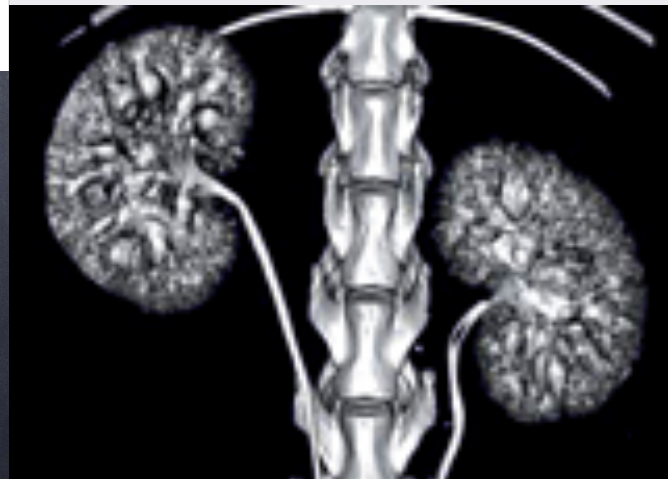
Preclinical Ultrasound

MRI

### microCT



Bildband



#### Location:

Zurich Integrative Rodent Physiology (ZIRP)  
Winterthurer Str. 190  
CH-8057 Zürich  
Phone: +41446355095  
[→ directions](#)

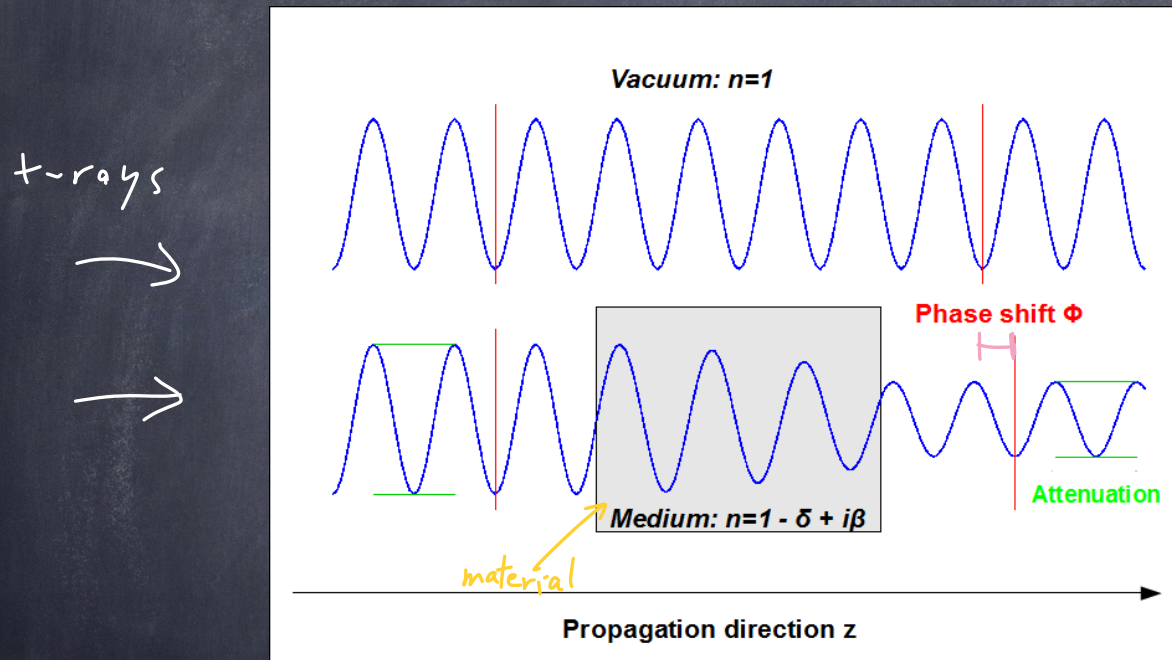
#### ZIRP news:

[news](#)  
[courses, lectures](#)

Another technique to improve CT scans:

## Phase-contrast X-ray imaging

with phase-contrast imaging, one observes the interference pattern between light passing through a material and light (x-rays) that doesn't pass through.



x-rays  
→  
→

2 things happen!

1) attenuation  
(amplitude is decreasing)

2) phase-shift

$n$ : index of refraction

phase shift is because  
the wavelength is different in materials  
with different  $n$ .

x-ray →



different refraction index

complex index of refraction:

$$n = 1 - \delta + i\beta$$

describes change in phase because of change in wavelength  
describes the absorption (extinction) coefficient

Electric field wave function:

$$E(x) = \epsilon_0 e^{inx}$$

↑  
initial amplitude

$n$ : index of refraction

$k$ : wave number,  $k = \frac{2\pi}{\lambda}$

$x$ : distance traveled

$$E(x) = \epsilon_0 e^{i(1-\delta)kx} e^{-\beta kx}$$

↑                      ↑  
phase shift            attenuation

complex math:

$$i^2 = -1 \quad \sqrt{-1} = i$$

$$e^{i\theta} = \underbrace{\cos\theta}_{\text{real part which we measure}} + i \underbrace{\sin\theta}_{\text{imaginary part}}$$

attenuation:  $\beta = \frac{\rho_a \sigma_a}{k}$

phase shift:  $\delta = \frac{\rho_a p}{k}$

$$\sigma_a = 0.02 \text{ [barns]} \left(\frac{k_0}{k}\right)^3 Z^4$$

substitute in values:  $\delta = \frac{2\pi \rho_a Z r_0}{k^2}$

$$\beta = 0.01 \text{ barn } \rho_a k_0^3 \left(\frac{Z}{k}\right)^4$$

we see that:  $\underbrace{\beta \propto k^{-4}}_{\text{attenuation}}, \underbrace{\delta \propto k^{-2}}_{\text{phase shift}}$

For human tissue,  $\delta$  is 3 orders of magnitude bigger than  $\beta$   
 $\rightarrow$  The phase shift is much larger than the attenuation  
 $\rightarrow$  More sensitive to differences in density  
 $\rightarrow k^{-4}$  vs  $k^{-2}$ : means the phase contrast benefit grows with increasing energy.

$k$ : wave number =  $\frac{2\pi}{\lambda}$

$\rho_a$ : atomic number density

$\sigma_a$ : absorption cross-section

$p$ : phase-shift cross-section

$p = \frac{2\pi Z r_0}{k}$       $Z$ : atomic number

$r_0$ : classical electron radius

1 barn =  $10^{-28} \text{ m}^2$

$k_0$ : length of wave with  $\lambda = 1 \text{ \AA} = 10^{-10} \text{ m}$

phase contrast approach has advantages over absorption approach

- different dependence on energy
- x-rays don't need to be absorbed → (less radiation dose)
- use higher energy x-rays that have less attenuation (less radiation dose)

Benefits of phase-contrast imaging:

- 1) more sensitive to differences in tissue density (tumor detection)
- 2) higher energy x-rays provide less dose
- 3) phase shift in soft tissue is mainly larger than the absorption.

# Absorption X-ray vs. phase-contrast X-ray

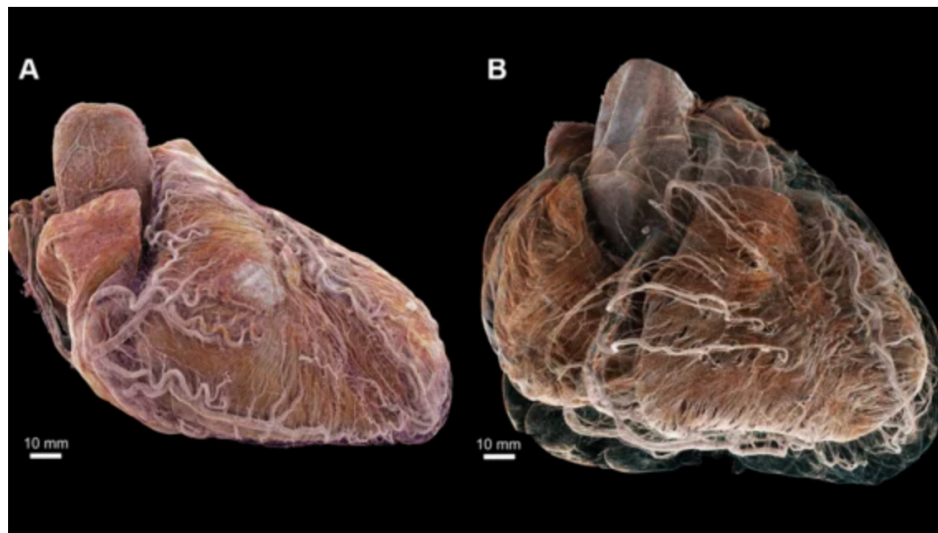


(In-ear headphone)

Always new developments going on

## New imaging technique captures human heart with 'unprecedented detail'

Michael Walter | July 17, 2024 | Cardiovascular Business | Cardiac Imaging



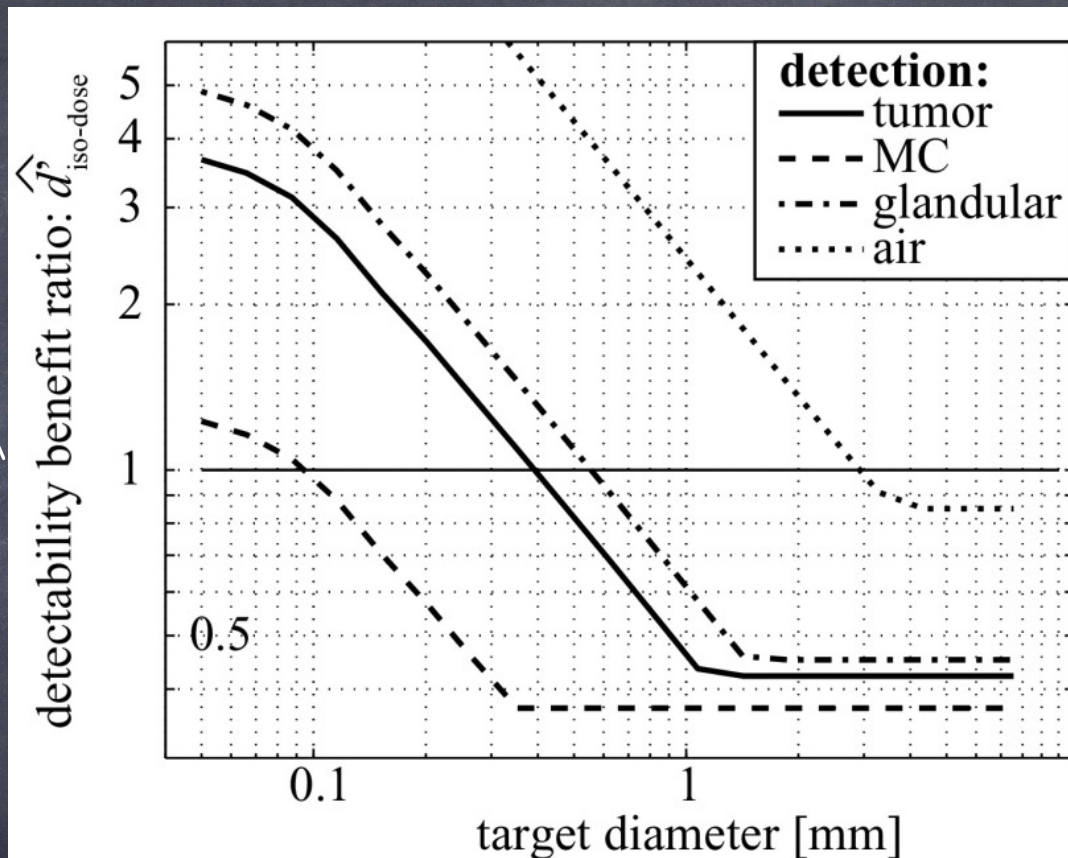
Images of the heart create using a new X-ray technique, hierarchical **phase-contrast tomography (HiP-CT)**. The technology enables CT imaging of the heart and the ability to zoom in to the cellular level with unprecedented detail. Images courtesy of RSNA.

[Link to article](#)

Benefit of phase contrast depends on tissue type & target size.

phase contrast relative to absorption

better if larger number ↑



The benefit of phase contrast mammography relative to absorption contrast for (1) a tumor structure ("tumor"), (2) a glandular structure ("glandular"), (3) a microcalcification ("MC"), and (4) an air cavity ("air") as a function of target size at optimal energy and equal dose.<sup>[97]</sup>

[https://en.wikipedia.org/wiki/Phase-contrast\\_X-ray\\_imaging#Phase-contrast\\_x-ray\\_imaging\\_in\\_medicine](https://en.wikipedia.org/wiki/Phase-contrast_X-ray_imaging#Phase-contrast_x-ray_imaging_in_medicine)

Another improvement to CT scans:

focussing X-rays

Lets us achieve nanoscale resolution

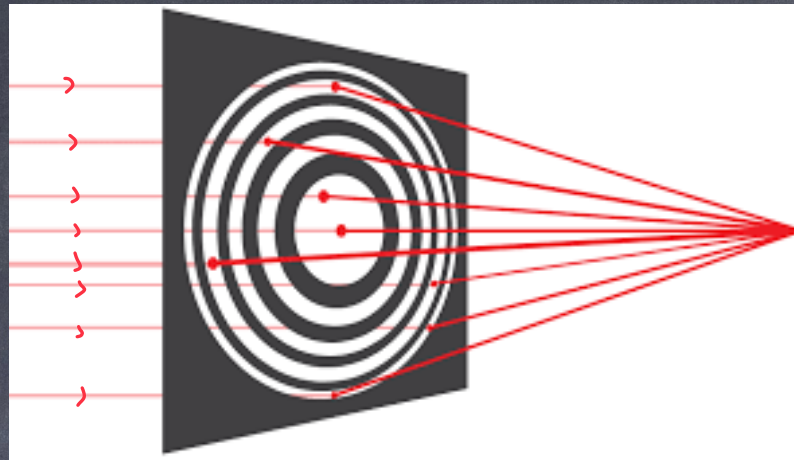
Here we use  
microwaves (7 cm)  
transmitter

Fresnel zone plate

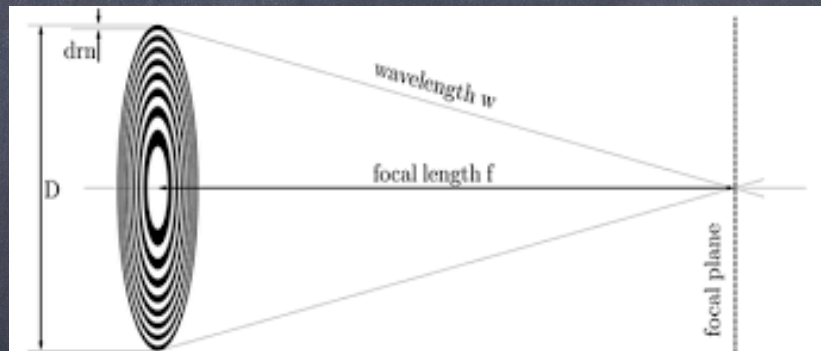


we can focus any EM wave like this.

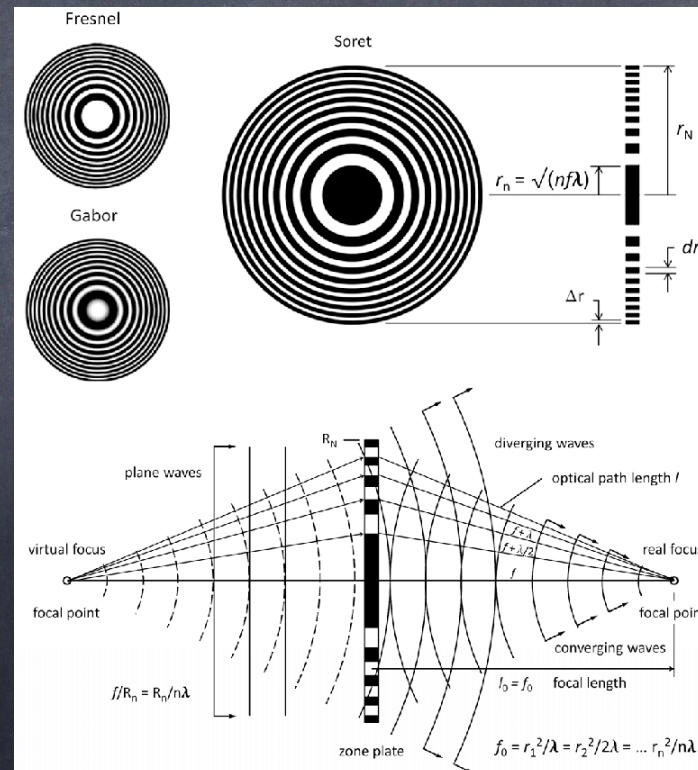
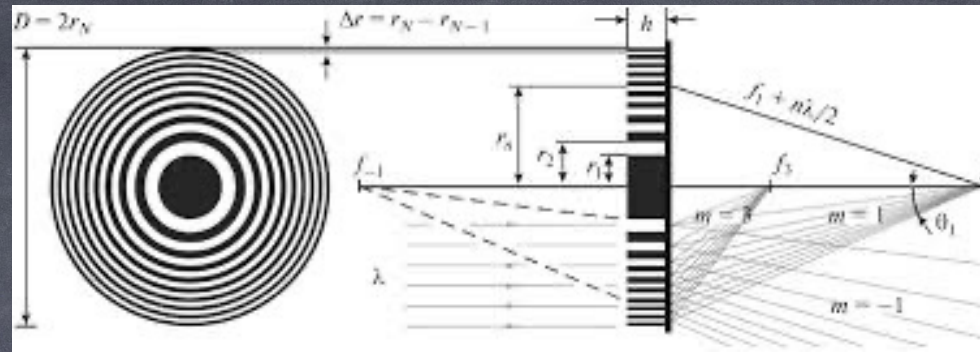
incoming  
EM  
waves



Focus



Geometry is tuned:  
 → radii of rings  
 →  $\Delta r$  between rings  
 → distance between rings + focus



## Fresnel zone plate:

to get constructive interference at the focus,  
the zones (radii) should switch between transparent  
and opaque at radii where

$$r_n = \sqrt{n\lambda f + \frac{1}{4}n^2\lambda^2}$$



↑ ↑ radii

$n$ : integer

$\lambda$ : wavelength of light

$f$ : distance from center of  
zone plate to the  
focus plane

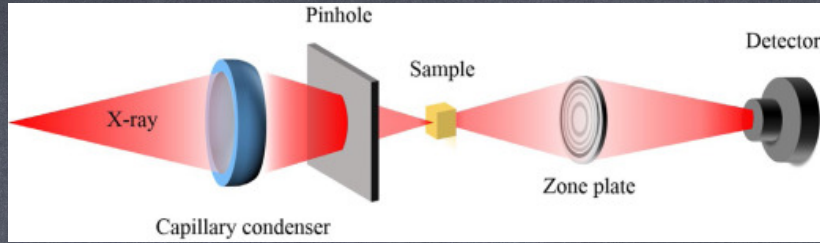
If zone plate is small compared to the  
focal length  $f$ , then

$$r_n \approx \sqrt{n\lambda f}$$

we can do this with t-rays as well

# Nano CT

For x-rays, Fresnel  
Zone plate is typically  
Gold, Nickel, Tungsten, Platinum, Iridium  
deposited on a silicon substrate  
using electron-beam lithography  
& electroplating



Combining small X-ray focal spots with cone beam geometry, this NanoCT setup reaches resolutions down to 100nm and is highly versatile respective to sample sizes<sup>10,16,17</sup>.

↑  
resolutions of  $\sim 100$  nm

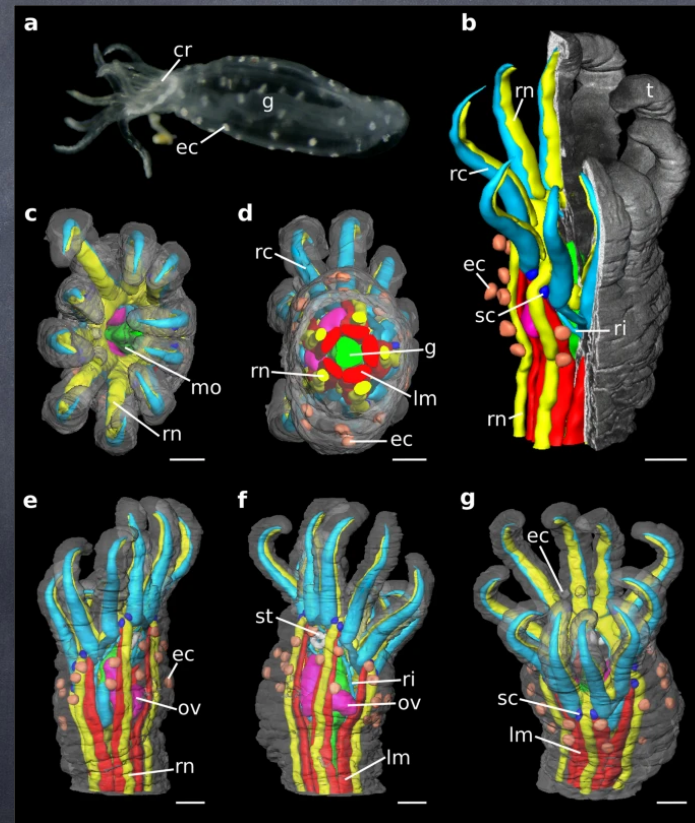
## Nanoscope X-ray tomography for correlative microscopy of a small meiofaunal sea-cucumber

Simone Ferstl , Thomas Schwaha, Bernhard Ruthensteiner, Lorenz Hehn, Sebastian Allner, Mark Müller, Martin Dierolf, Klaus Achterhold & Franz Pfeiffer

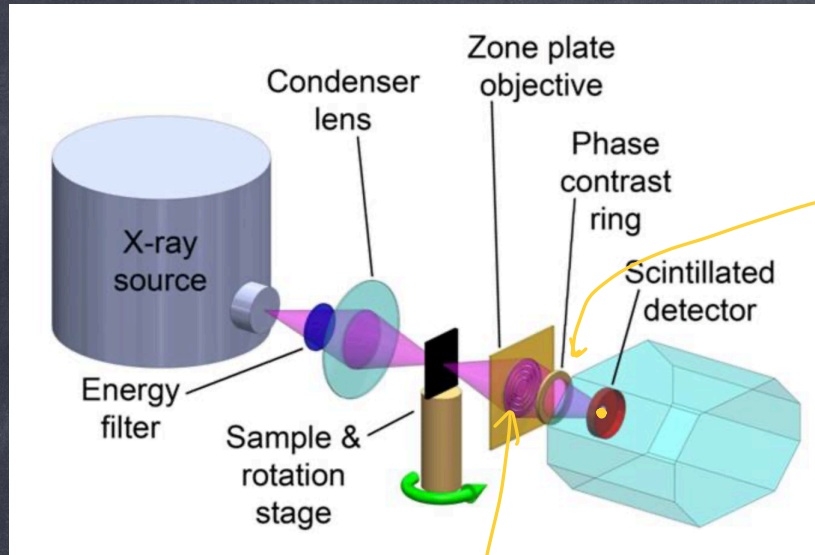
*Scientific Reports* 10, Article number: 3960 (2020) | [Cite this article](#)

<https://www.nature.com/articles/s41598-020-60977-5>

## Worm $\sim 1$ mm length



# Combining techniques for more precise imaging



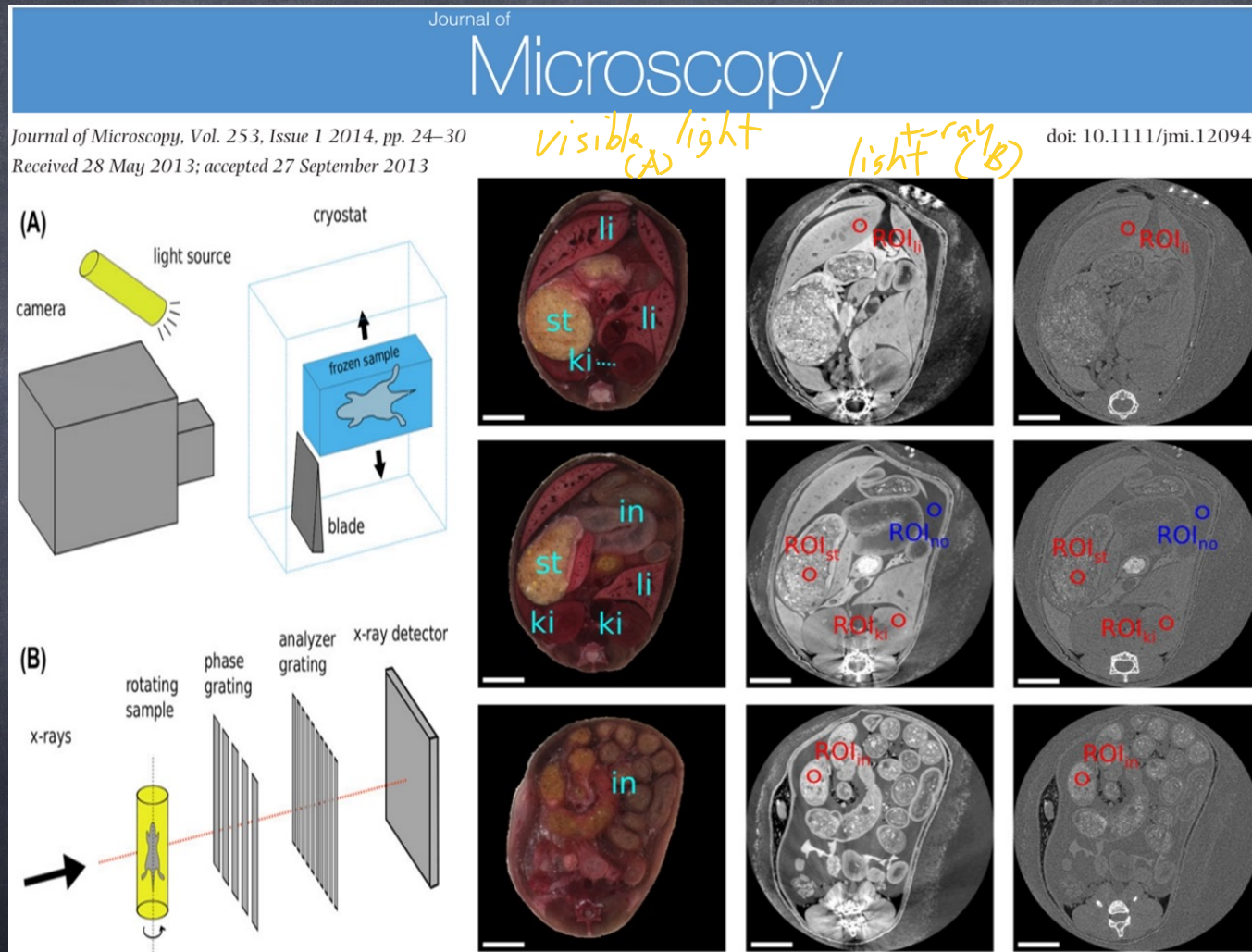
phase-contrast ring  
(thickness tuned to  $\frac{\pi}{2}$  phase shift)

<https://www.cmu.edu/me/xctf/facility/index.html>

Fresnel  
zone  
plate

The UltraXRM-L200 achieves its resolution using a laboratory X-ray source (rotating copper anode) that emits X-ray with a photon energy level of 8 keV. As the schematic below shows, the X-ray beam passes through a mono-capillary condenser lens that uses grazing incidence reflection to efficiently focus the X-rays on the sample. This efficient condenser is key to using a laboratory X-ray source rather than a synchrotron beam. After passing the sample, the X-rays are focused onto the detector using a Fresnel zone plate objective. The zone plate objective consists of high aspect ratio concentric gold rings. The maximum resolution of an X-ray transmission microscope is related to the minimum spacing of the gold rings. The 35 nm spacing of the high resolution zone plate in the UltraXRM-L200 yields a theoretical Rayleigh criterion resolution of 43 nm. After the zone plate, the X-ray beam passes by a gold phase ring for Zernike phase contrast (if in phase contrast mode). The ring phase shifts X-rays not diffracted by the sample, causing interference between the undiffracted X-rays and those diffracted by the sample and resulting in a negative phase contrast image. Subsequently, the X-rays intercept a scintillation screen coupled to a CCD detector.

# Benefits of x-rays vs. microscopes (visible light)



To improve x-rays further, we need ultrashort, high-intensity pulses of x-rays. This gives us quick exposures and time resolution of fast processes. Besides x-ray tubes, x-rays can be produced by synchrotrons.

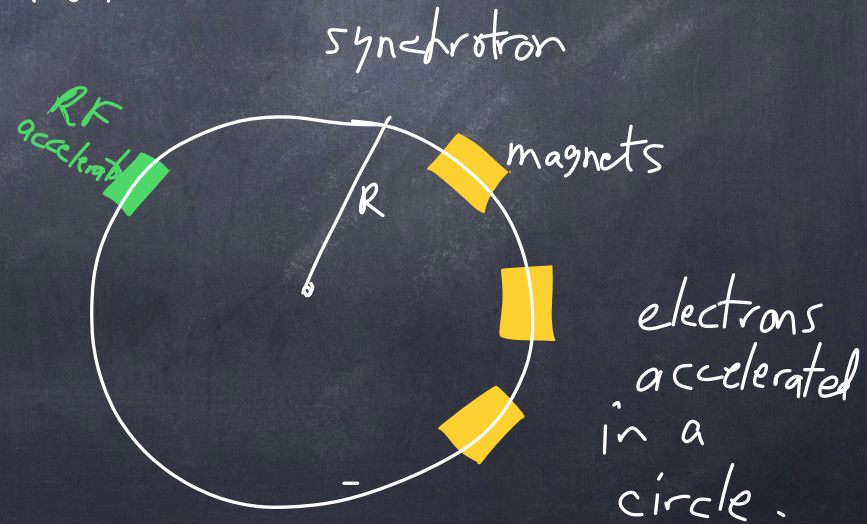
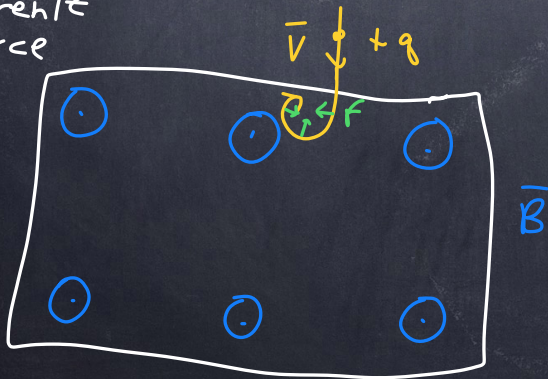
The Large Hadron Collider (LHC) at CERN is the world's largest synchrotron.

The Swiss Light Source (SLS) at PSI is the most relevant for today.

How does a Synchrotron work?

$$\vec{F} = q \vec{v} \times \vec{B}$$

Lorentz force



synchrotrons  
accelerate  
charged  
particles

$$\vec{F}_B = q\vec{v} \times \vec{B} = qvB \quad \text{if } \vec{v} \perp \vec{B}$$

provides centripetal acceleration,  $F_c = \frac{mv^2}{R}$

set  $F_B = F_c$

$$qvB = \frac{mv^2}{R}$$

$$qB = \frac{mv}{R}$$

momentum =  $p = mv$  (classical momentum)

$$B = \frac{p}{qR}$$

$$R = \frac{p}{qB}$$

complication: relativistic momentum,  $p = mv\gamma$

$$\gamma = \frac{1}{\sqrt{1 - \frac{v^2}{c^2}}}$$

$c$ : speed of light

The orbital frequency  $\nu = \frac{\omega}{2\pi}$        $\omega = \frac{v}{R}$        $v$  (velocity)

$$\nu = \frac{v}{2\pi R} = \frac{mv}{m2\pi R} = \frac{p}{R} \frac{1}{2\pi m} = \frac{p}{\frac{p}{qB}} \cdot \frac{1}{2\pi m} = \frac{qB}{2\pi m}$$

This needs a relativistic correction because time slows down for fast ( $v \approx c$ ) particles,

$$\nu = \frac{qB}{2\pi m} \sqrt{1 - \frac{v^2}{c^2}} \leftarrow \frac{1}{\gamma}$$

In a synchrotron, the magnetic field is increased as the particle momentum increases, because the radius constant.

So  $p + B$  increase together.

# Examples of synchrotrons

## European Synchrotron Radiation Facility (ESRF) in Grenoble, France

13 member countries: France, Germany, Italy, the UK, Spain, Switzerland, Belgium, the Netherlands, Denmark, Finland, Norway, Sweden, Russia

World's  
largest



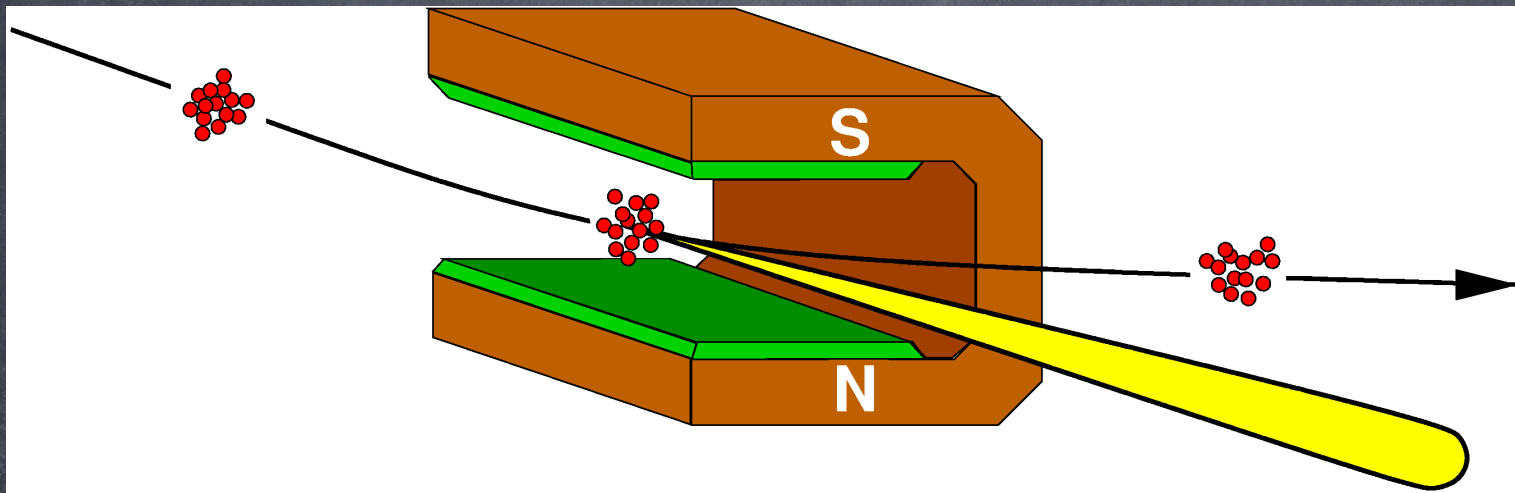
10,000 billion more powerful than X-rays used in the medical field.

## Swiss Light Source (SLS) at PSI, Switzerland (45 minutes away)



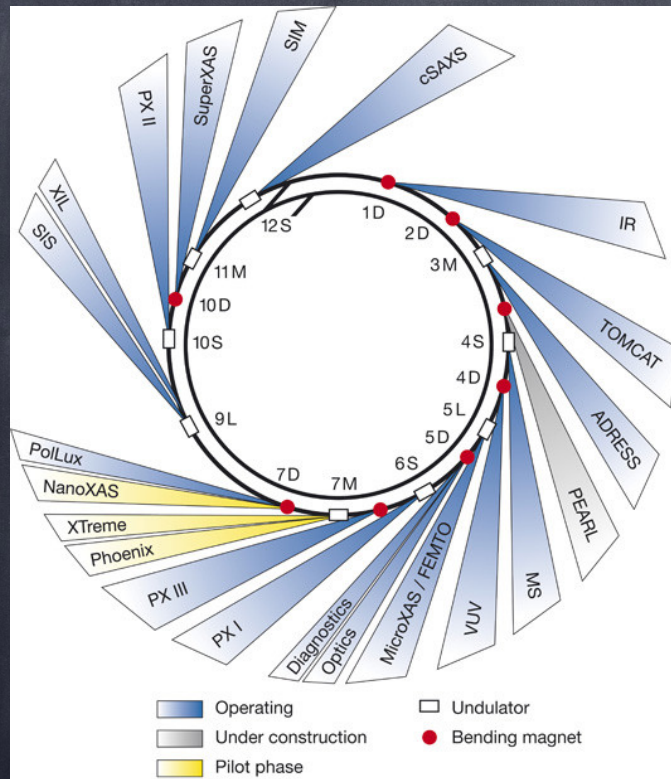
How are x-rays produced in a synchrotron?

electron bunches  
↓



↑  
pulse  
of  
x-rays

# Swiss Light Source (SLS)



**TOMCAT** ( A beamline for  
T**Omographic** M**icroscopy** and C**oherent**  
r**Adiology** experimen**Ts** )  
<https://www.psi.ch/en/sls/tomcat>

## TOMCAT beam line

Technical Data	
Energy range	8-45 keV
Highest 3D spatial resolution	ca. 1 $\mu\text{m}$ in parallel beam geometry ca. 200 nm in full-field geometry
Max. temporal resolution	20 Hz
Available techniques	<ul style="list-style-type: none"> <li>- Absorption-based tomographic microscopy</li> <li>- Propagation-based phase contrast tomographic microscopy</li> <li>- Ultra-fast tomographic microscopy</li> <li>- Grating interferometry</li> <li>- Absorption and <u>phase contrast</u> nanotomography</li> </ul>
Available devices for in situ sample conditioning	<ul style="list-style-type: none"> <li>- Laser-based heating system</li> <li>- Cryojet and cryo-chamber</li> </ul>

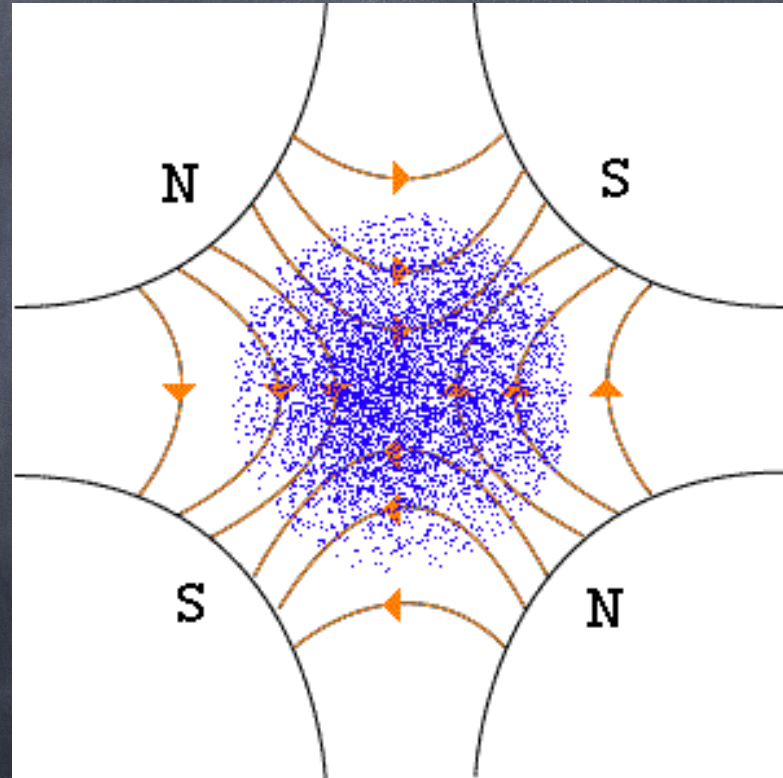
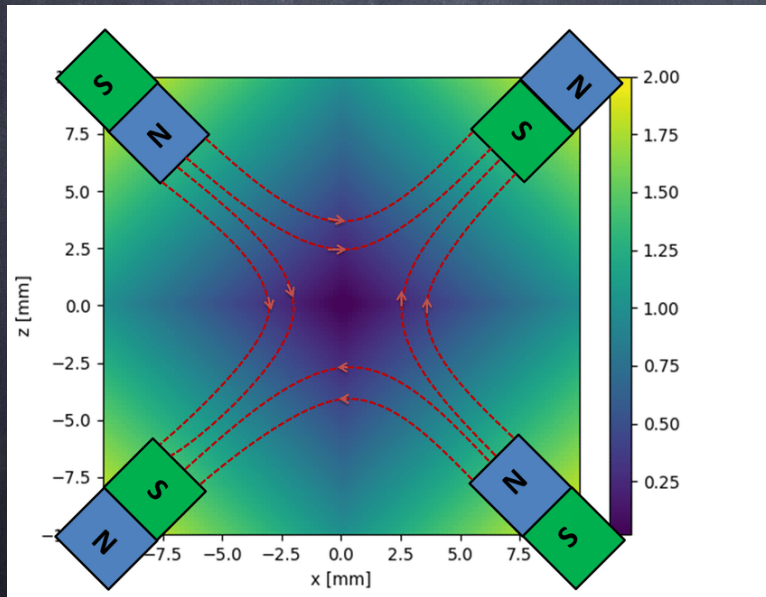
### 65 nm pixel size (resolution)

Absorption-based and phase contrast imaging are routinely performed with isotropic voxel sizes ranging from 0.16 to 11  $\mu\text{m}$  (fields-of-view (h x v) of 0.4 x 0.3 mm<sup>2</sup> and 22 x 3-7 mm<sup>2</sup>, respectively) in an energy range of 8-45 keV. Phase contrast is obtained with simple edge-enhancement, propagation-based techniques [2, 3] or through grating interferometry [4].

A temporal resolution of a few (< 5) minutes can also be achieved with the hard X-ray full-field microscope setup [8] delivering a pixel size of 65 nm for microscopic samples (~75x75  $\mu\text{m}^2$  field-of-view).

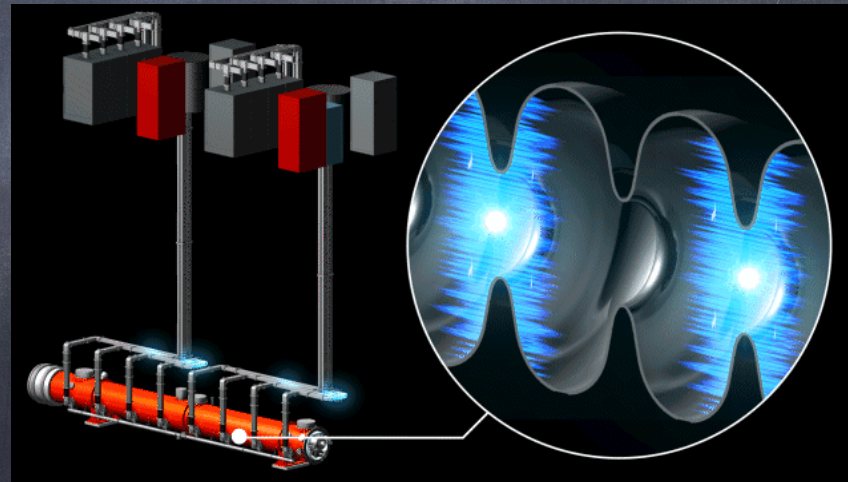
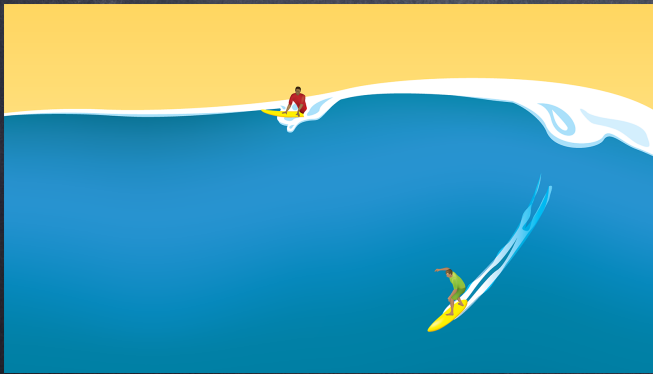
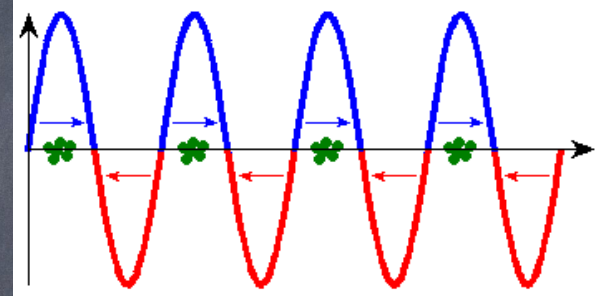
Beam optics focus  
electron bunches: we want small bunches so  
t-ray pulse is precise

quadrupole magnets are used for  
some focusing:



# How to accelerate electrons

## RF acceleration (YouTube video here <https://www.youtube.com/watch?v=mu4m7wSnpD0>)



Superconducting RF cavities

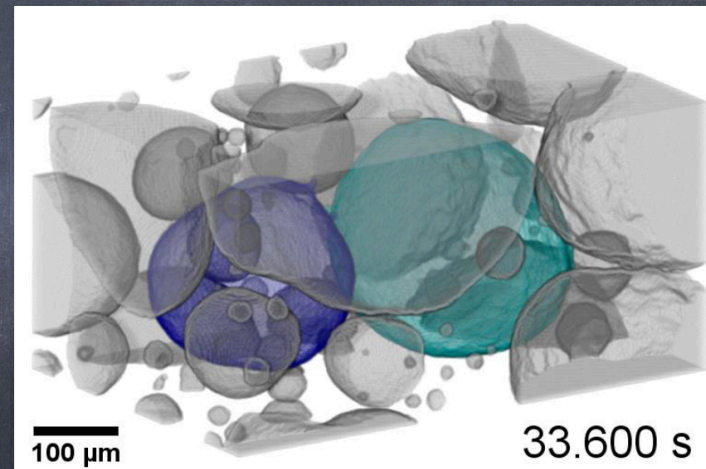
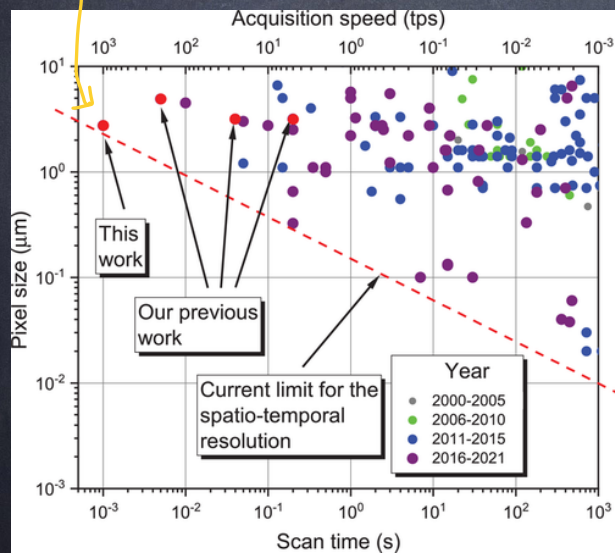
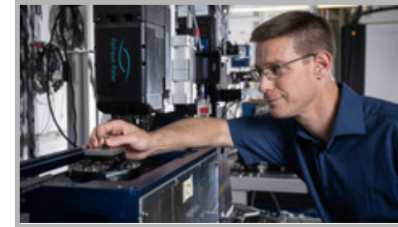
Time resolution  
with  
synchrotrons

24 September 2021

## X-ray microscopy with 1000 tomograms per second

Research Using Synchrotron Light Materials Research Matter and Material

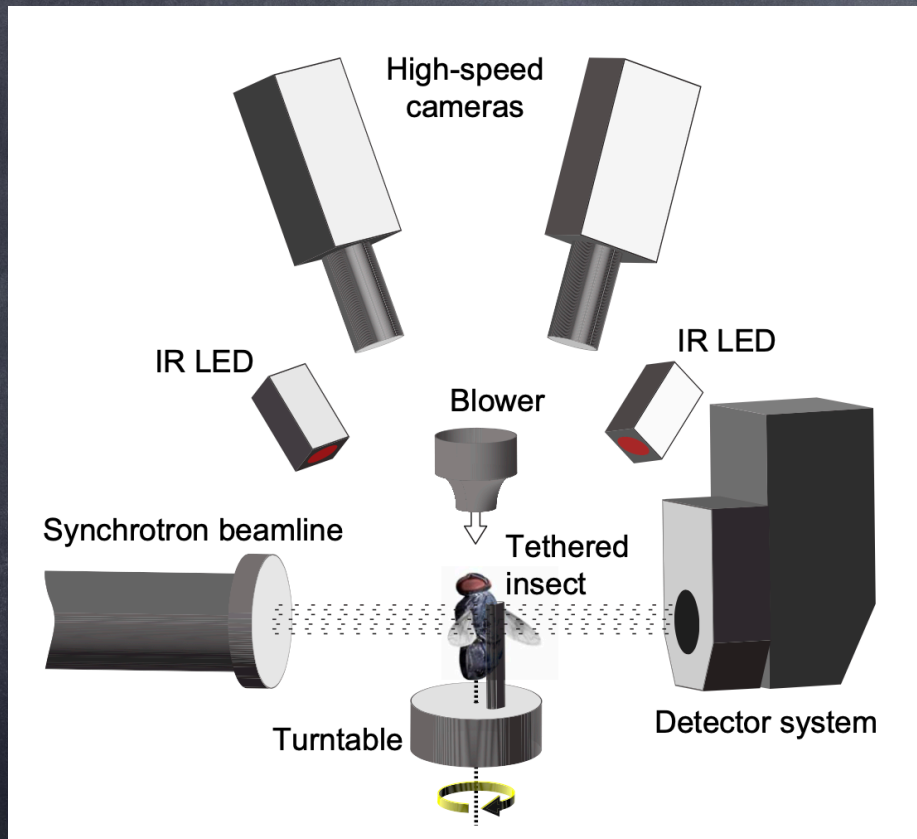
A team at the Swiss Light Source SLS have set a new record using an imaging method called tomography.



100  $\mu\text{m}$  Bubble coalescence

<https://onlinelibrary.wiley.com/doi/10.1002/adma.202104659>

An example of time resolved CT  
using synchrotron

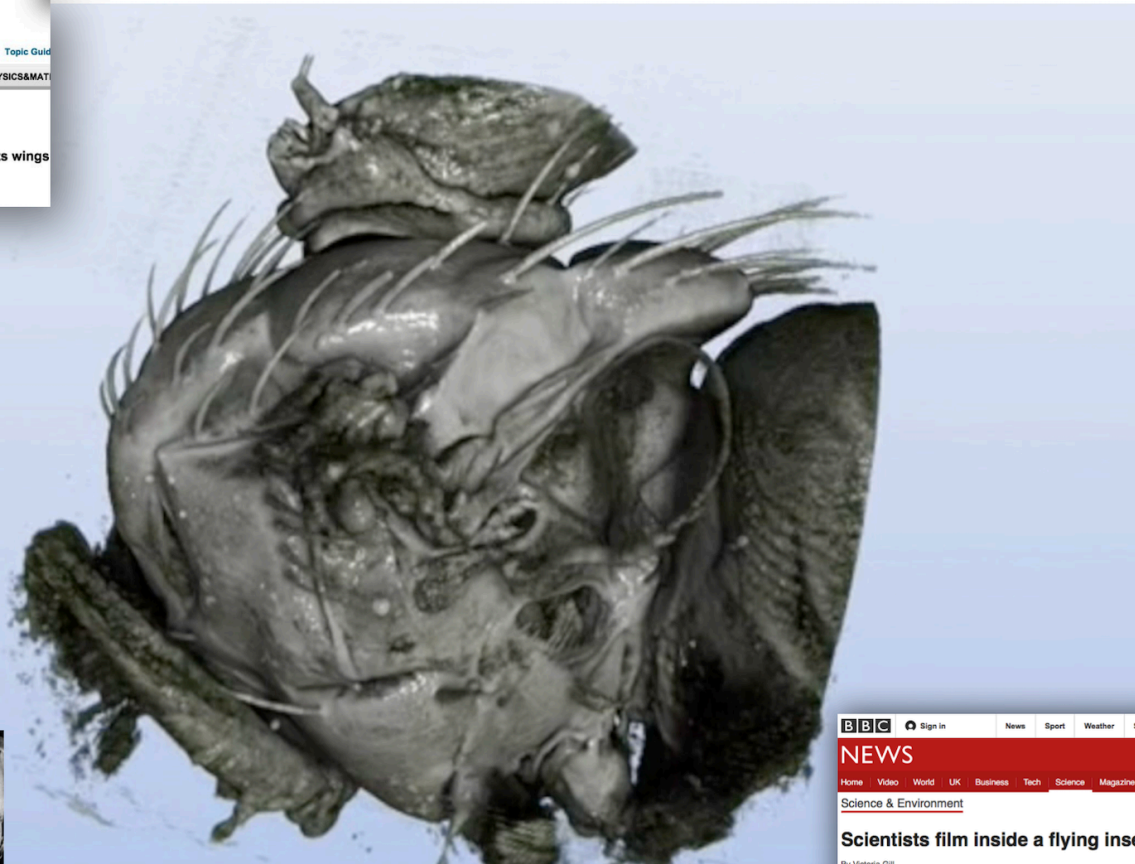
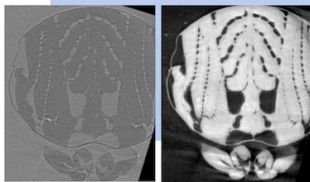


<https://doi.org/10.1371/journal.pbio.1001823>

<https://pubmed.ncbi.nlm.nih.gov/18682361/>

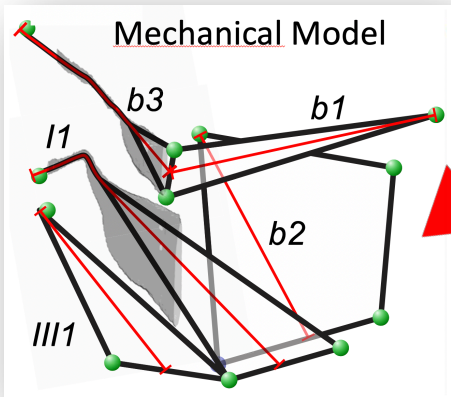
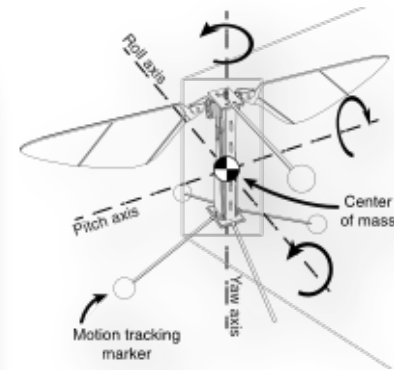
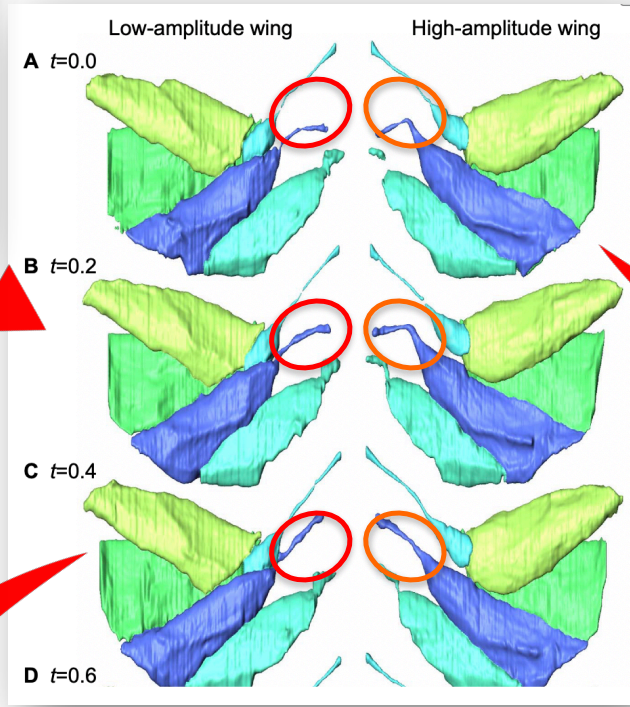
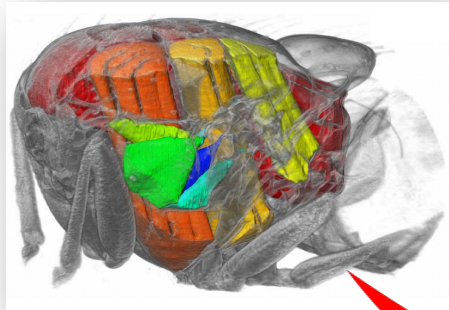
# Muscles and tracheal network *during* flight

Von Prof. Marco Stampanoni / ETHZ und PSI



Walker et al., PloS Biology (2014) & Mokso et al., SciRep (2015)

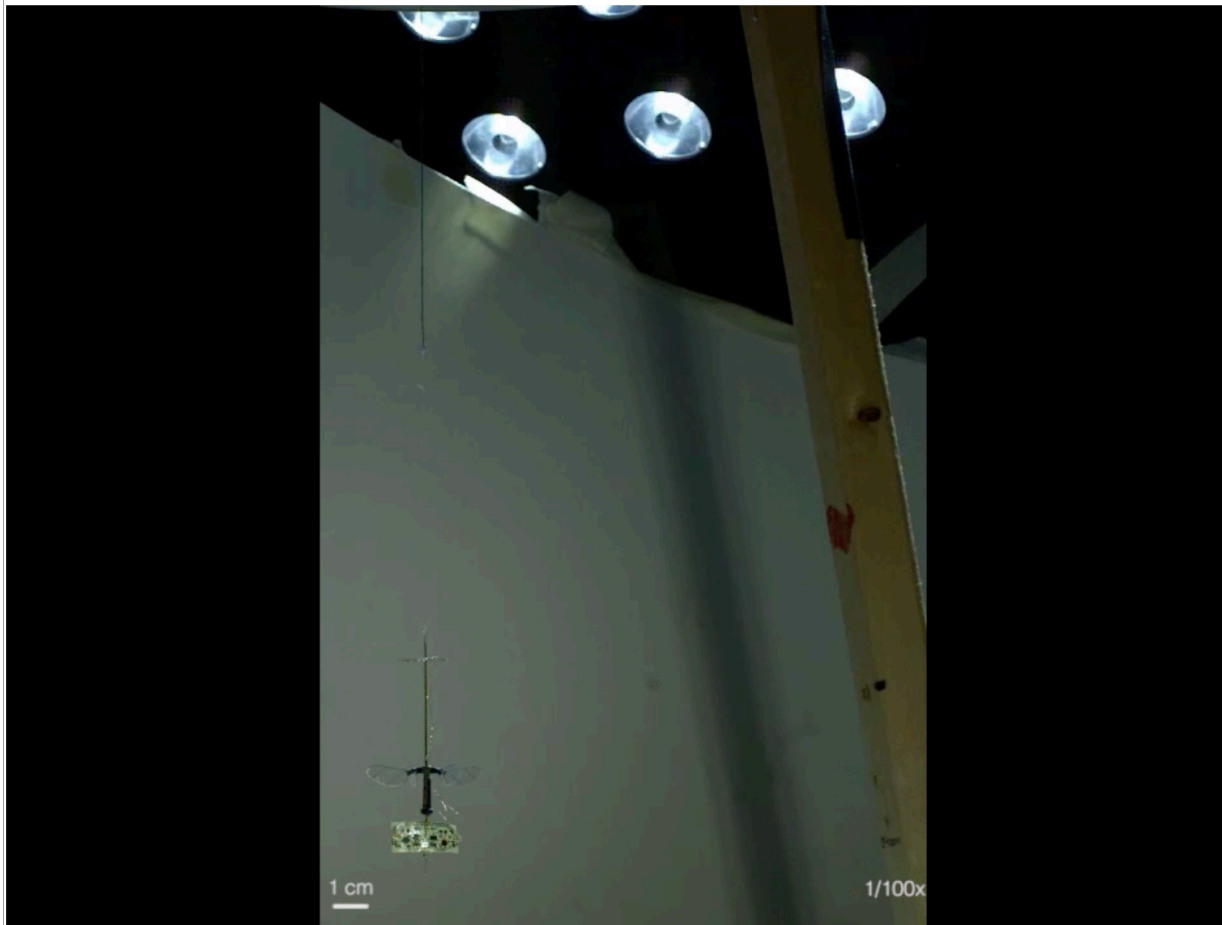
Dynamic X-ray microscopy boosting the development of bio-inspired robotics



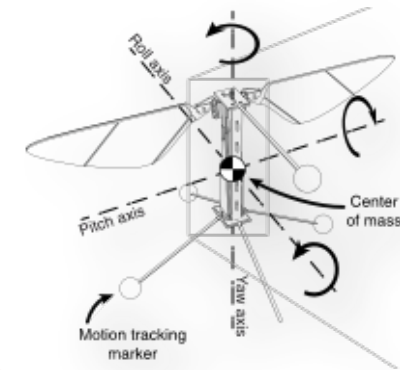
Walker S. et al., PloS Biology (2014)

Jafferis et al., Nature 2019

### Dynamic X-ray microscopy boosting the development of bio-inspired robotics

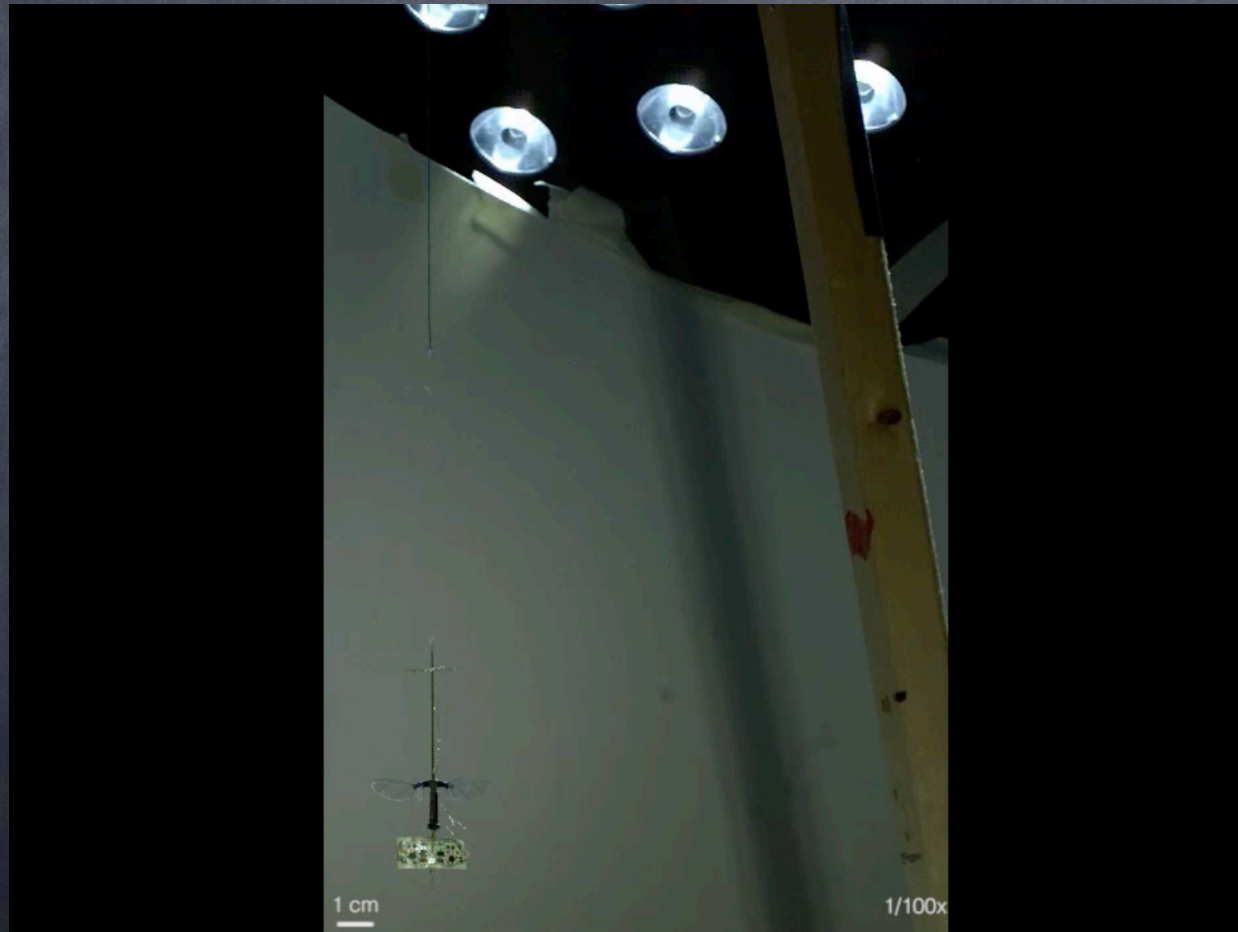


Walker S. et al., PloS Biology (2014)



Jafferis et al., Nature 2019

An application of learning how flies "fly"  
and making robots to do it the same way.



we want 4-D imaging  
3-D in space + time

→ How to get the  
best resolution?

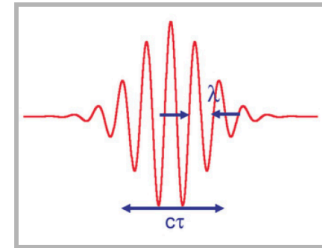
Best →

(FEL)  
Free Electron  
laser

spatial  
+  
temporal  
resolution

(laser  
good time  
resolution)

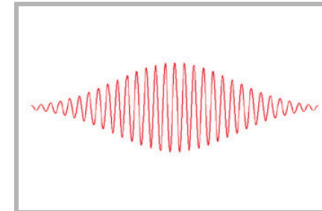
synchrotrons  
poor time  
resolution,  
good position  
resolution



Wanted: short spatial and temporal resolution



Lasers have poor spatial resolution due to long wavelength



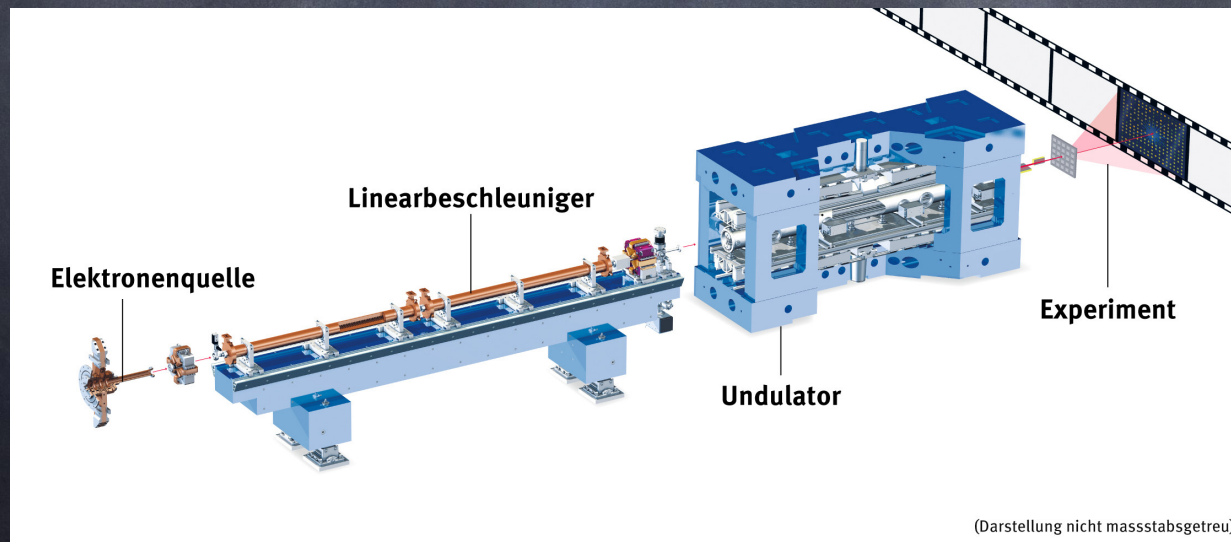
Synchrotrons have a poor temporal resolution due to the long pulse length



FELs fulfill both demands

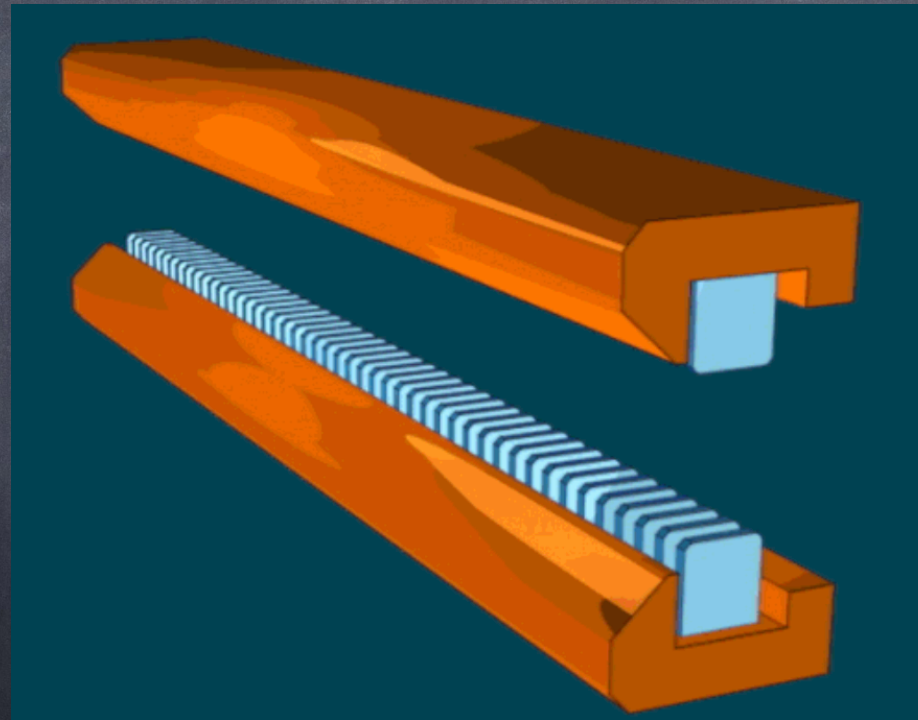
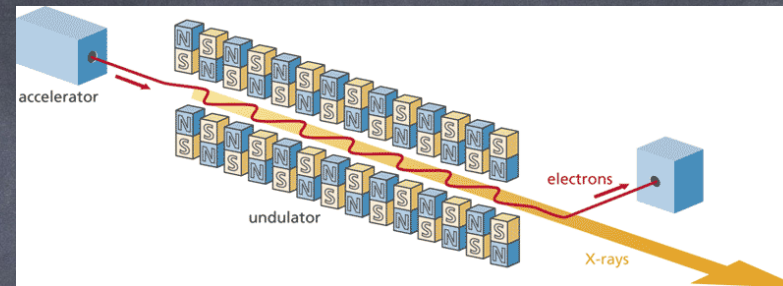
# PSI Swiss FEL

Free electron lasers make ultra-compact pulses of x-rays with amazing spatial + temporal resolution

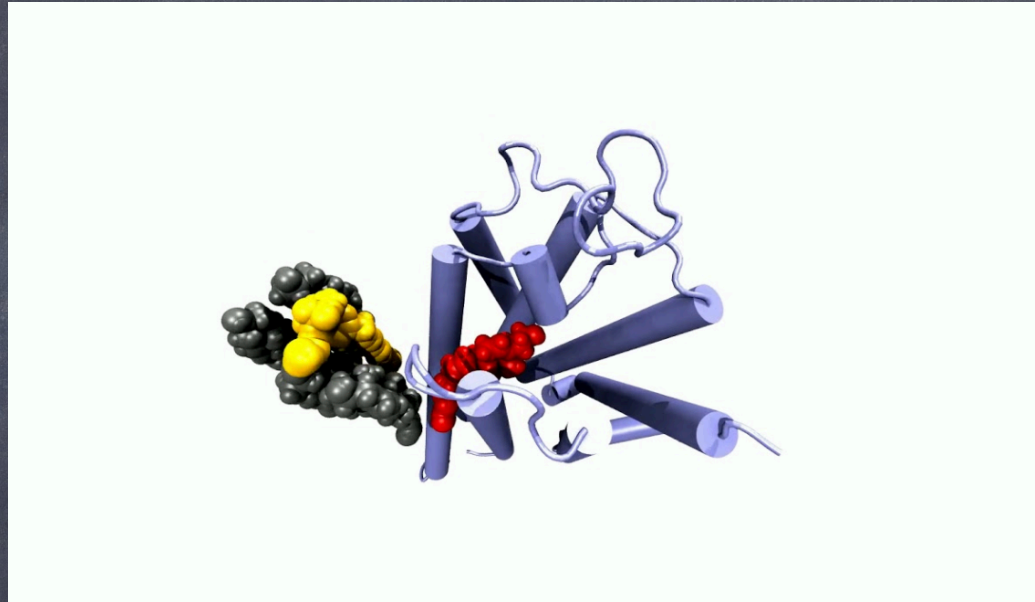


How a FEL works!

## Undulator



# X-ray free-electron laser SwissFEL



Watching receptor proteins change shape

Comparison of time and space resolution	Conventional laser	Synchrotron	Free-electron laser
Wavelength	100 nm	0.1 nm	0.1 nm
Time pulse	10 fs ( $10 \times 10^{-15}$ s)	100 ps ( $100 \times 10^{-12}$ s)	10 fs ( $10 \times 10^{-15}$ s)
Summary	Can resolve larger scales at ultrafast speeds	Can resolve atomic scale and fast processes	Can resolve atomic scale and ultrafast processes

## Some references :

<https://www.microphotonics.com/what-is-micro-ct-an-introduction/>

<https://www.microphotonics.com/how-does-a-microct-scanner-work/>

Laboratory x-ray micro-computed tomography: a user guideline for biological samples

<https://www.ncbi.nlm.nih.gov/pmc/articles/PMC5449646/>

Useful references for a variety of radiation techniques :

<https://astronuclphysics.info/Scintigrafie.htm#3>

<https://astronuclphysics.info/JadRadMetody.htm>