

Axion-Like Particle Generation with the Free-Electron Laser VUV-FEL

A. Ringwald

<http://www.desy.de/~ringwald>



- AR, "Fundamental physics at an X-ray free-electron laser," arXiv:hep-ph/0112254
- R. Rabadan, AR and K. Sigurdson, "Photon regeneration from pseudoscalars at X-ray laser facilities," arXiv:hep-ph/0511103
- U. Kötz, AR and T. Tschentscher, "Production and detection of axion-like particles at the VUV-FEL: A study of feasibility," in progress

Seminar, Universität Zürich
January 11, 2006, Zürich, Switzerland

Table of Content:

1. **ALP** Searches

Previous laboratory limits and recent evidence

2. **ALP** Interpretation

Theoretical and astrophysical difficulties of recent evidence

3. **ALP** Generation

Free-electron laser VUV-FEL as an ALP generator to probe recent evidence

4. **ALP** Outlook

1. ALP Searches

- Many models beyond the Standard Model:

New light pseudoscalar particles, very weakly coupled to ordinary matter

- Would arise if there was a global continuous symmetry in the theory that is spontaneously broken in the vacuum

Axion, arising from the breaking of a U(1) Peccei-Quinn symmetry introduced to explain the absence of strong CP violation

[Peccei, Quinn (1977); S. Weinberg (1978); Wilczek (1978)]

- Such pseudoscalars couple to two photons via

$$\mathcal{L}_{\phi\gamma\gamma} = -\frac{1}{4} g \phi F_{\mu\nu} \tilde{F}^{\mu\nu} = g \phi \vec{E} \cdot \vec{B}$$

⇒ In the presence of a magnetic field \vec{B} , a photon of frequency ω may oscillate into a pseudoscalar particle of mass $m_\phi < \omega$, and vice versa

[Sikivie (1983); Ansel'm (1985); van Bibber *et al.* (1987); Raffelt, Stodolsky (1988)]

Photon regeneration

- **Production:** Polarized laser beam along transverse magnetic field, such that $\mathbf{E} \parallel \mathbf{B} \Rightarrow$ conversion $\gamma \rightarrow \phi$
- Absorb laser beam in wall
- **Detection:** Detect photons behind wall from back conversion ($\phi \rightarrow \gamma$) in second magnetic field:

$$\dot{N}_\gamma = \underbrace{\frac{\langle P \rangle}{\omega}}_{\dot{N}_0} \frac{N_r}{2} \underbrace{\frac{1}{16} (g B \ell)^4 F^2(q\ell)}_{P^2_{\gamma \leftrightarrow \phi}}$$

with $F \approx 1$ for $q\ell \ll 1$ (coherence),

$$m_\phi \lesssim 10^{-3} \text{ eV} \left(\frac{\omega}{1 \text{ eV}} \frac{1 \text{ m}}{\ell} \right)^{1/2}$$

“Light shining through a wall”

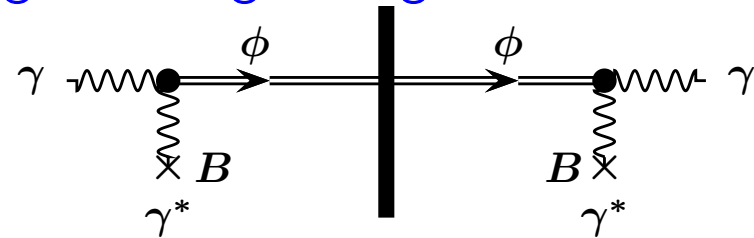

[Sikivie (1983); Ansel'm (1985); Van Bibber *et al.* (1987)]

BFRT experiment:

(Brookhaven, Fermilab, Rochester, Trieste)

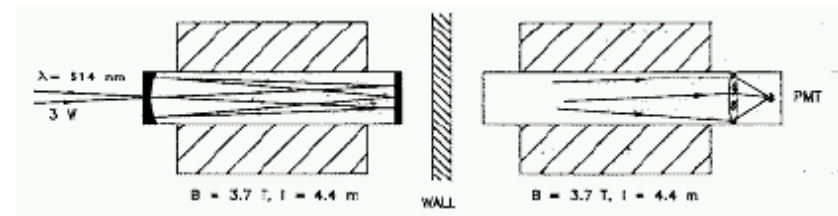

[Cameron *et al.* (1993)]

$$B = 3.7 \text{ T}, \ell = 4.4 \text{ m}, \underbrace{\langle P \rangle = 3 \text{ W}, \omega = 2.4 \text{ eV}}_{\dot{N}_0 = 8 \times 10^{18} / \text{s}}, N_r = 200$$

Photon regeneration

- **Production:** Polarized laser beam along transverse magnetic field, such that $\mathbf{E} \parallel \mathbf{B} \Rightarrow$ conversion $\gamma \rightarrow \phi$
- Absorb laser beam in wall
- **Detection:** Detect photons behind wall from back conversion ($\phi \rightarrow \gamma$) in second magnetic field:

$$\dot{N}_\gamma = \underbrace{\frac{\langle P \rangle}{\omega}}_{\dot{N}_0} \frac{N_r}{2} \underbrace{\frac{1}{16} (g B \ell)^4 F^2(q\ell)}_{P_{\gamma \leftrightarrow \phi}^2} g \quad [\text{GeV}^{-1}]$$

with $F \approx 1$ for $q\ell \ll 1$ (coherence),

$$m_\phi \lesssim 10^{-3} \text{ eV} \left(\frac{\omega}{1 \text{ eV}} \frac{1 \text{ m}}{\ell} \right)^{1/2}$$

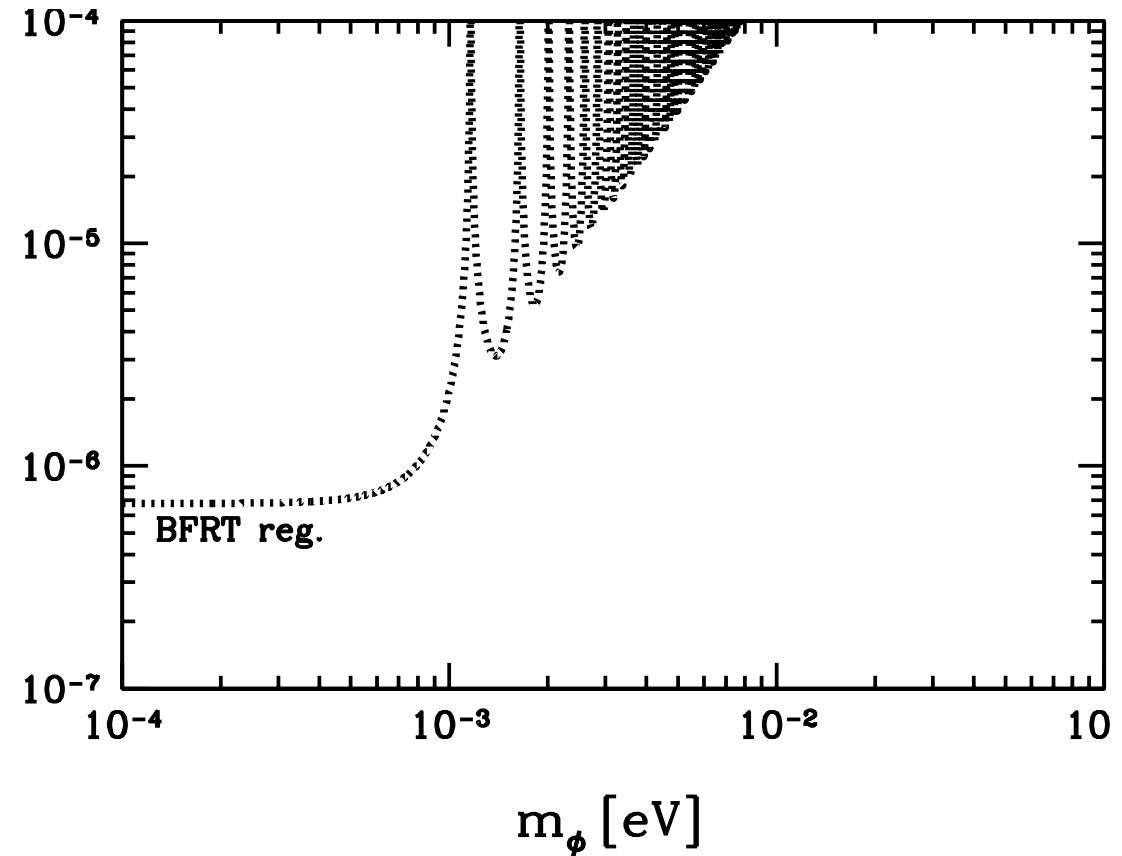

Polarization experiments

- Send linearly polarized laser beam through transverse magnetic field \Rightarrow measure changes in polarization state
- Real and virtual production induce
 - **rotation**: photons polarized $\parallel \mathbf{B}$ will disappear leading to apparent rotation of polarization plane by

$$\varepsilon_\phi = -N_r \left(\frac{gB\ell}{4} \right)^2 F(q\ell) \sin 2\theta$$

- **ellipticity**: virtual production causes retardation between \mathbf{E}_{\parallel} and $\mathbf{E}_{\perp} \Rightarrow$ elliptic polarization

$$\psi_\phi \approx \frac{N_r}{6} \left(\frac{gB\ell}{4} \right)^2 \frac{m_\phi^2 \ell}{\omega} \sin 2\theta$$

for small masses, $m_\phi^2 \ell / 4\omega \ll 1$.

A. Ringwald (DESY)

“Vacuum magnetic dichroism and birefringence”

[Maiani, Petronzio, Zavattini '86]

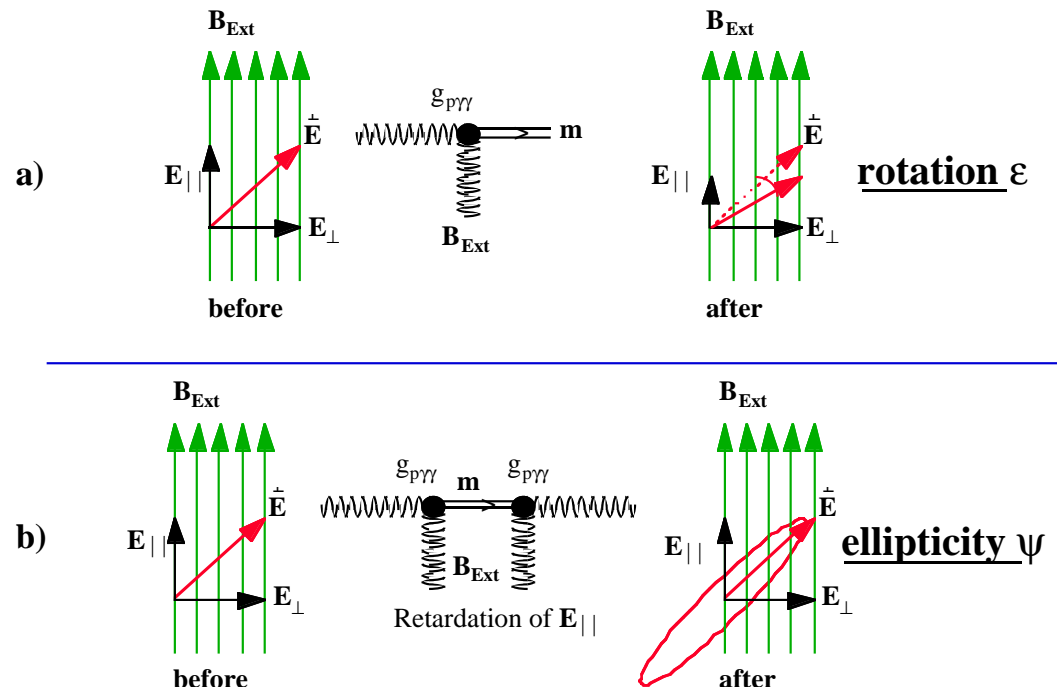

[Brandi *et al.* '01]

Seminar, Zürich, Switzerland

Polarization experiments

- Send linearly polarized laser beam through transverse magnetic field \Rightarrow measure changes in polarization state
- Real and virtual production induce
 - **rotation:** photons polarized $\parallel \mathbf{B}$ will disappear leading to apparent rotation of polarization plane by

$$\varepsilon_\phi = -N_r \left(\frac{gB\ell}{4} \right)^2 F(q\ell) \sin 2\theta$$

- **ellipticity:** virtual production causes retardation between \mathbf{E}_\parallel and $\mathbf{E}_\perp \Rightarrow$ elliptic polarization

$$\psi_\phi \approx \frac{N_r}{6} \left(\frac{gB\ell}{4} \right)^2 \frac{m_\phi^2 \ell}{\omega} \sin 2\theta$$

for small masses, $m_\phi^2 \ell / 4\omega \ll 1$.

A. Ringwald (DESY)

BFRT experiment: [Cameron *et al.* (1993)]

$$B = 2 \text{ T}, \ell = 8.8 \text{ m}, \omega = 2.4 \text{ eV}, N_r = 34 - 254$$

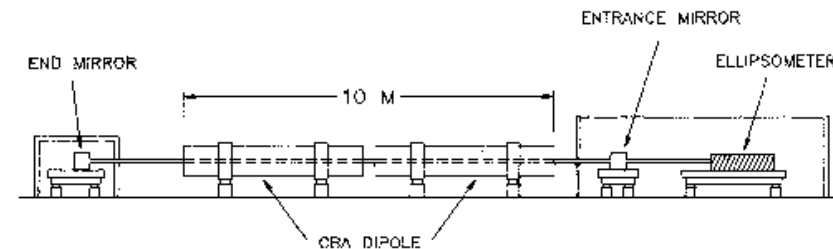

Seminar, Zürich, Switzerland

Polarization experiments

- Send linearly polarized laser beam through transverse magnetic field \Rightarrow measure changes in polarization state
- Real and virtual production induce
 - **rotation:** photons polarized $\parallel \mathbf{B}$ will disappear leading to apparent rotation of polarization plane by

$$\varepsilon_\phi = -N_r \left(\frac{gB\ell}{4} \right)^2 F(q\ell) \sin 2\theta$$

- **ellipticity:** virtual production causes retardation between \mathbf{E}_\parallel and $\mathbf{E}_\perp \Rightarrow$ elliptic polarization

$$\psi_\phi \approx \frac{N_r}{6} \left(\frac{gB\ell}{4} \right)^2 \frac{m_\phi^2 \ell}{\omega} \sin 2\theta$$

for small masses, $m_\phi^2 \ell / 4\omega \ll 1$.

A. Ringwald (DESY)

BFRT experiment: [Cameron *et al.* (1993)]

$B = 2 \text{ T}$, $\ell = 8.8 \text{ m}$, $\omega = 2.4 \text{ eV}$, $N_r = 254$

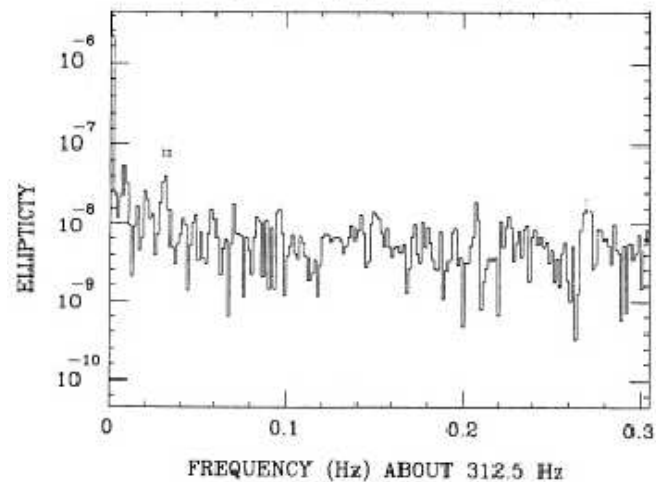
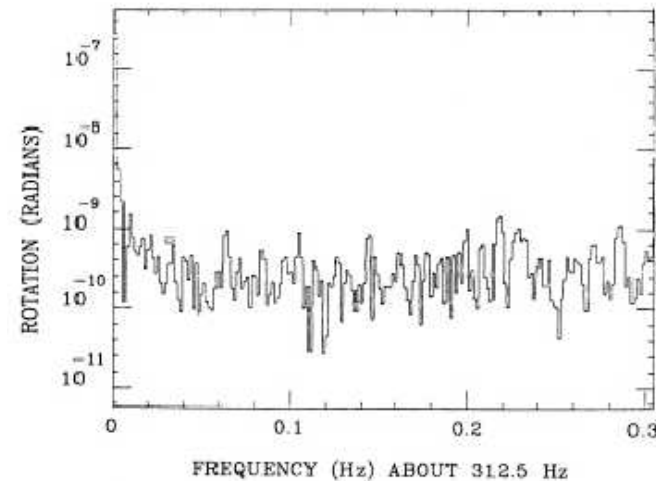

Seminar, Zürich, Switzerland

Polarization experiments

- Send linearly polarized laser beam through transverse magnetic field \Rightarrow measure changes in polarization state
- Real and virtual production induce
 - **rotation:** photons polarized $\parallel B$ will disappear leading to apparent rotation of polarization plane by

$$\varepsilon_\phi = -N_r \left(\frac{g B \ell}{4} \right)^2 F(q\ell) \sin 2\theta$$

- **ellipticity:** virtual production causes retardation between \mathbf{E}_\parallel and $\mathbf{E}_\perp \Rightarrow$ elliptic polarization

$$\psi_\phi \approx \frac{N_r}{6} \left(\frac{g B \ell}{4} \right)^2 \frac{m_\phi^2 \ell}{\omega} \sin 2\theta$$

for small masses, $m_\phi^2 \ell / 4\omega \ll 1$.

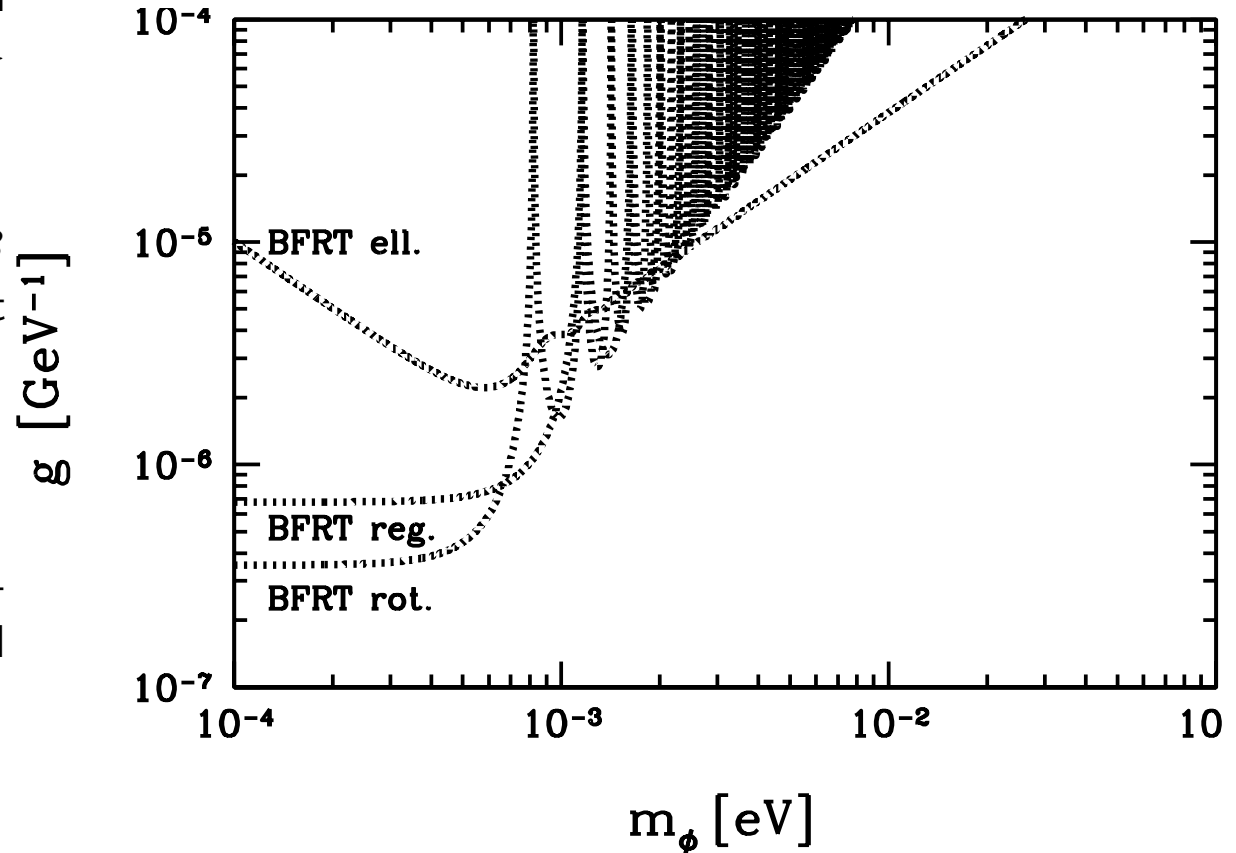

Polarization experiments

- Send linearly polarized laser beam through transverse magnetic field \Rightarrow measure changes in polarization state
- Real and virtual production induce
 - **rotation:** photons polarized $\parallel \mathbf{B}$ will disappear leading to apparent rotation of polarization plane by

$$\varepsilon_\phi = -N_r \left(\frac{gB\ell}{4} \right)^2 F(q\ell) \sin 2\theta$$

- **ellipticity:** virtual production causes retardation between \mathbf{E}_\parallel and $\mathbf{E}_\perp \Rightarrow$ elliptic polarization

$$\psi_\phi \approx \frac{N_r}{6} \left(\frac{gB\ell}{4} \right)^2 \frac{m_\phi^2 \ell}{\omega} \sin 2\theta$$

for small masses, $m_\phi^2 \ell / 4\omega \ll 1$.

A. Ringwald (DESY)

PVLAS experiment: [Zavattini et al. '05]

$B = 5 \text{ T}$, $\ell = 1 \text{ m}$, $\omega = 1.2 \text{ eV}$, $N_r = 44000$

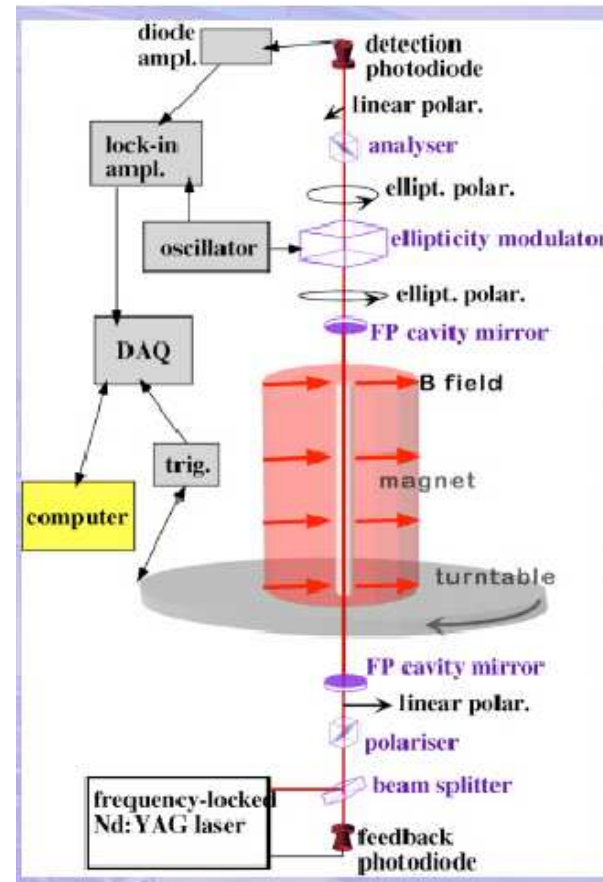

[Cantatore, IDM 2004]

Seminar, Zürich, Switzerland

Polarization experiments

- Send linearly polarized laser beam through transverse magnetic field \Rightarrow measure changes in polarization state
- Real and virtual production induce
 - **rotation:** photons polarized $\parallel \mathbf{B}$ will disappear leading to apparent rotation of polarization plane by

$$\varepsilon_\phi = -N_r \left(\frac{gB\ell}{4} \right)^2 F(q\ell) \sin 2\theta$$

- **ellipticity:** virtual production causes retardation between \mathbf{E}_\parallel and $\mathbf{E}_\perp \Rightarrow$ elliptic polarization

$$\psi_\phi \approx \frac{N_r}{6} \left(\frac{gB\ell}{4} \right)^2 \frac{m_\phi^2 \ell}{\omega} \sin 2\theta$$

for small masses, $m_\phi^2 \ell / 4\omega \ll 1$.

A. Ringwald (DESY)

PVLAS experiment: [Zavattini *et al.* '05]

$B = 5 \text{ T}$, $\ell = 1 \text{ m}$, $\omega = 1.2 \text{ eV}$, $N_r = 44000$

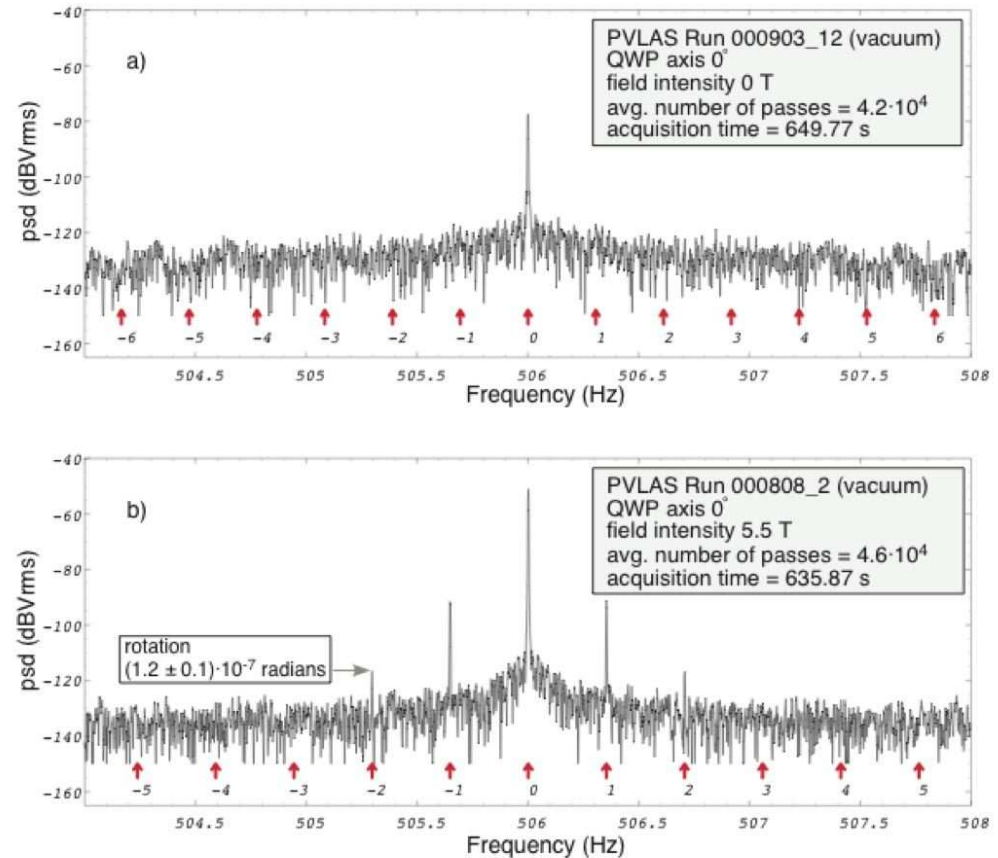

[Zavattini *et al.* '05]

Seminar, Zürich, Switzerland

Polarization experiments

- Send linearly polarized laser beam through transverse magnetic field \Rightarrow measure changes in polarization state
- Real and virtual production induce
 - **rotation:** photons polarized $\parallel B$ will disappear leading to apparent rotation of polarization plane by

$$\varepsilon_\phi = -N_r \left(\frac{g B \ell}{4} \right)^2 F(q\ell) \sin 2\theta$$

- **ellipticity:** virtual production causes retardation between \mathbf{E}_\parallel and $\mathbf{E}_\perp \Rightarrow$ elliptic polarization

$$\psi_\phi \approx \frac{N_r}{6} \left(\frac{g B \ell}{4} \right)^2 \frac{m_\phi^2 \ell}{\omega} \sin 2\theta$$

for small masses, $m_\phi^2 \ell / 4\omega \ll 1$.

A. Ringwald (DESY)

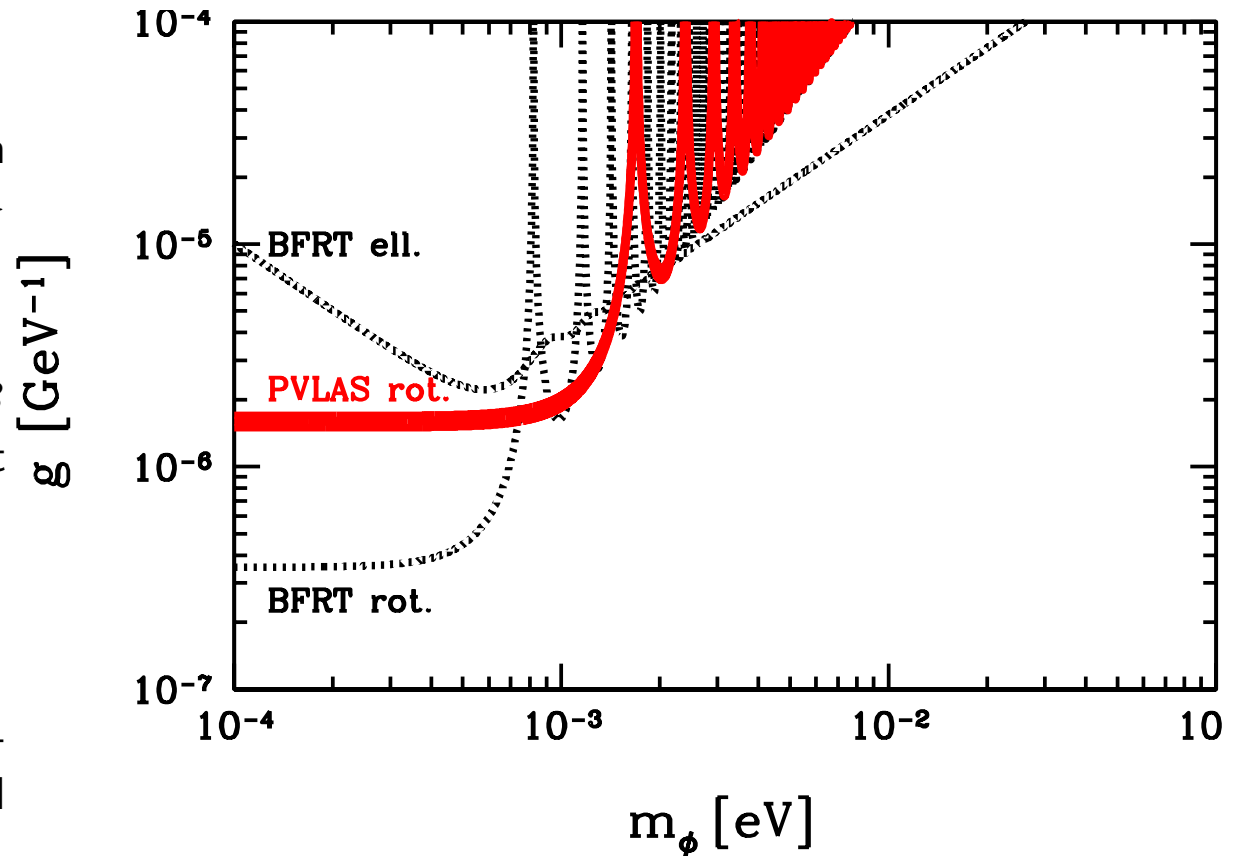

Publication:

[Zavattini et al. '05]

$$1.7 \times 10^{-6} \text{ GeV}^{-1} \lesssim g \lesssim 1.0 \times 10^{-5} \text{ GeV}^{-1}$$

$$0.7 \text{ meV} \lesssim m_\phi \lesssim 2.0 \text{ meV}$$

Seminar, Zürich, Switzerland

Polarization experiments

- Send linearly polarized laser beam through transverse magnetic field \Rightarrow measure changes in polarization state
- Real and virtual production induce
 - **rotation:** photons polarized $\parallel B$ will disappear leading to apparent rotation of polarization plane by

$$\varepsilon_\phi = -N_r \left(\frac{gB\ell}{4} \right)^2 F(q\ell) \sin 2\theta$$

- **ellipticity:** virtual production causes retardation between \mathbf{E}_\parallel and $\mathbf{E}_\perp \Rightarrow$ elliptic polarization

$$\psi_\phi \approx \frac{N_r}{6} \left(\frac{gB\ell}{4} \right)^2 \frac{m_\phi^2 \ell}{\omega} \sin 2\theta$$

for small masses, $m_\phi^2 \ell / 4\omega \ll 1$.

A. Ringwald (DESY)

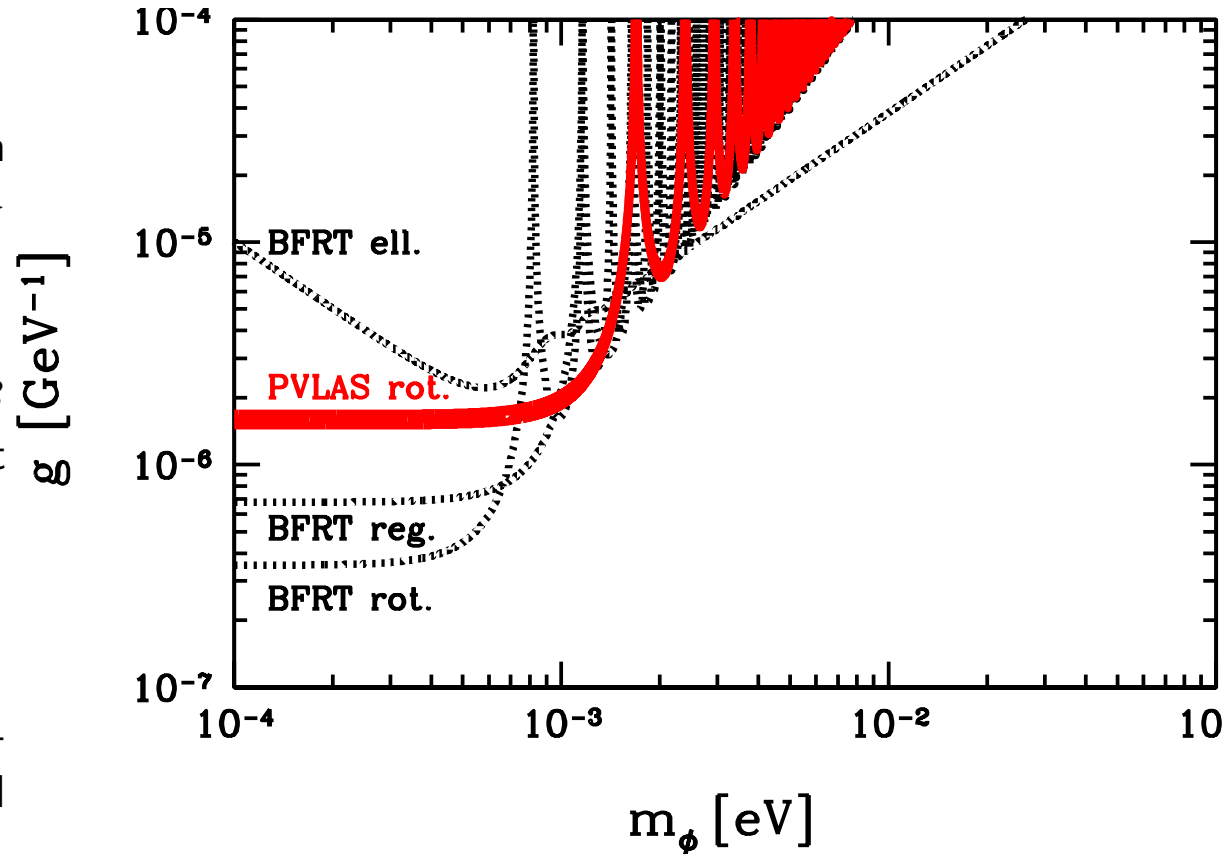

Including photon regeneration:

$$1.8 \times 10^{-6} \text{ GeV}^{-1} \lesssim g \lesssim 5.9 \times 10^{-6} \text{ GeV}^{-1}$$

$$1.0 \text{ meV} \lesssim m_\phi \lesssim 1.5 \text{ meV}$$

Seminar, Zürich, Switzerland

2. ALP Interpretation

- PVLAS ALP hardly compatible with standard QCD axion:

[Weinberg '78; Bardeen, Tye '78; . . .]

$$m_A = [z^{1/2}/(1+z)] m_\pi f_\pi / f_A = 0.6 \text{ meV} \times (10^{10} \text{ GeV} / f_A)$$

$$g_{A\gamma} = -\frac{\alpha}{2\pi f_A} \left(\frac{E}{N} - \frac{2}{3} \frac{4+z}{1+z} \right); \quad z = m_u/m_d = 0.56$$

- $m_A \sim 1 \text{ meV}$ implies a symmetry breaking scale $f_A \sim 6 \times 10^9 \text{ GeV}$
- Need extremely large ratio $|E/N| \sim 3 \times 10^7$ of electromagnetic and color anomalies in order to arrive at $g_{A\gamma} \sim 5 \times 10^{-6} \text{ GeV}^{-1}$
- All models conceived so far have $|E/N| = \mathcal{O}(1)$

– Axion-Like Particle Generation . . . –

- PVLAS ALP must have peculiar properties in order to evade strong constraints on g from

- stellar energy loss
- non-observation of ALP's in helioscopes such as the **CERN Axion Solar Telescope**

- How to solve the solar axion problem?

⇒ Need mechanism that avoids excessive energy loss/transfer in the sun or other stars:

- suppress ALP production
- trap ALP's

in stellar interior

A. Ringwald (DESY)

[Masso,Redondo '05; Jain,Mandal '05]

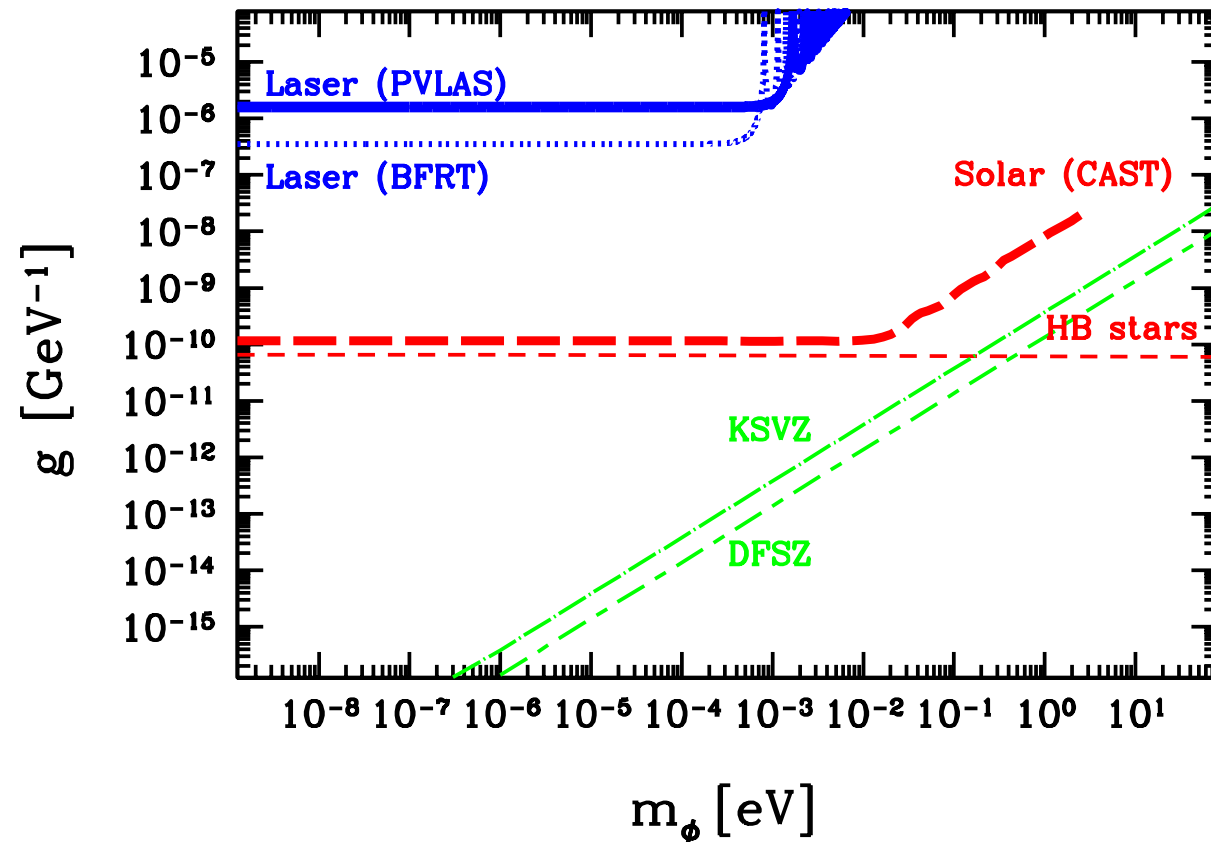

Seminar, Zürich, Switzerland

- In the center of the sun/stars where most ALP's are produced the environment is different from the environment of the PVLAS experiment:
 1. high temperature
 2. high density (at least compared to vacuum)
 3. large electromagnetic fields involved in the Primakoff process
 4. large neutrino flux compared to the one at the surface of the earth

⇒ If m_ϕ and g depend on environment,

$$m_\phi \rightarrow m_\phi(\text{environment}), \quad g \rightarrow g(\text{environment}),$$

in a suitable way, the production of ALP's inside the sun/stars may be strongly suppressed.

[Jäckel,Masso,Redondo,AR,Takahashi, in preparation]

Temperature suppression:

In sun/star: average virtuality of background photon $q^2 \sim T^2 \sim \text{keV}^2$

In PVLAS: $q^2 = m_\phi^4 / (4\omega^2) \sim 7 \times 10^{-13} \text{ eV}^2$

- Introduce form factor suppression for coupling $g \rightarrow g(q^2)$
 - ⇐ ALP composite [Masso, Redondo '05]
 - ⇐ Large renormalization group running of wave function renormalization (e.g. strong dynamics of ϕ or extra dimensions)
- Compatible with PVLAS and CAST, if $g(q^2)$ rapidly approaches zero for $q^2 > q_0^2$, where [Jäckel, Masso, Redondo, AR, Takahashi, in preparation]

$$(8 \times 10^{-7} \text{ eV})^2 < q_0^2 < (0.15 \text{ keV})^2$$

3. ALP Generation

- Independent and decisive experimental test of the pseudoscalar interpretation of the PVLAS observation is urgently needed
- Proposals:
 - Search for events with a single photon plus missing transverse energy in the final state at high luminosity e^+e^- colliders, e.g. a possible super- B factory at KEK [Masso,Toldra '97; Kleban,Rabadan '05]
 - New polarization experiments, e.g. BMV
 - New photon regeneration experiments at CERN and at DESY

- **Conversion probability** of photon send along magnetic field:

$$P_{\gamma \leftrightarrow \phi} \approx \frac{1}{4} g^2 B^2 \ell^2 \left(\frac{\sin \left(\frac{m_\phi^2 \ell}{4\omega} \right)}{\frac{m_\phi^2 \ell}{4\omega}} \right)^2$$

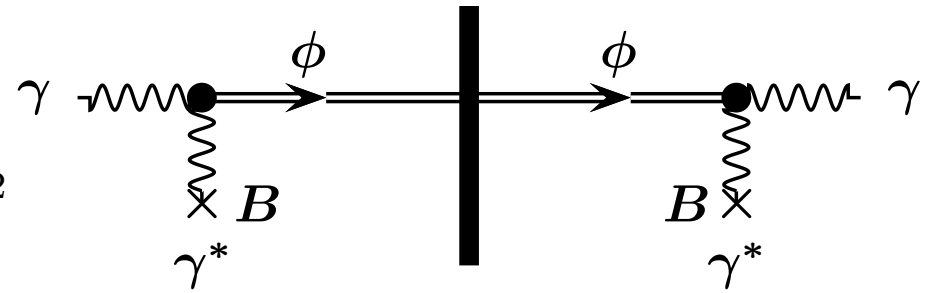

- **Conversion probability** of photon send along magnetic field:

$$P_{\gamma \leftrightarrow \phi} \approx \frac{1}{4} g^2 B^2 \ell^2 \left(\frac{\sin \left(\frac{m_\phi^2 \ell}{4\omega} \right)}{\frac{m_\phi^2 \ell}{4\omega}} \right)^2$$

- ⇒ **Photon regeneration** optimal
- for large $B\ell$ ⇒ recycle dipole magnets from accelerators

HERA dipole ($B\ell = 50 \text{ Tm}$):

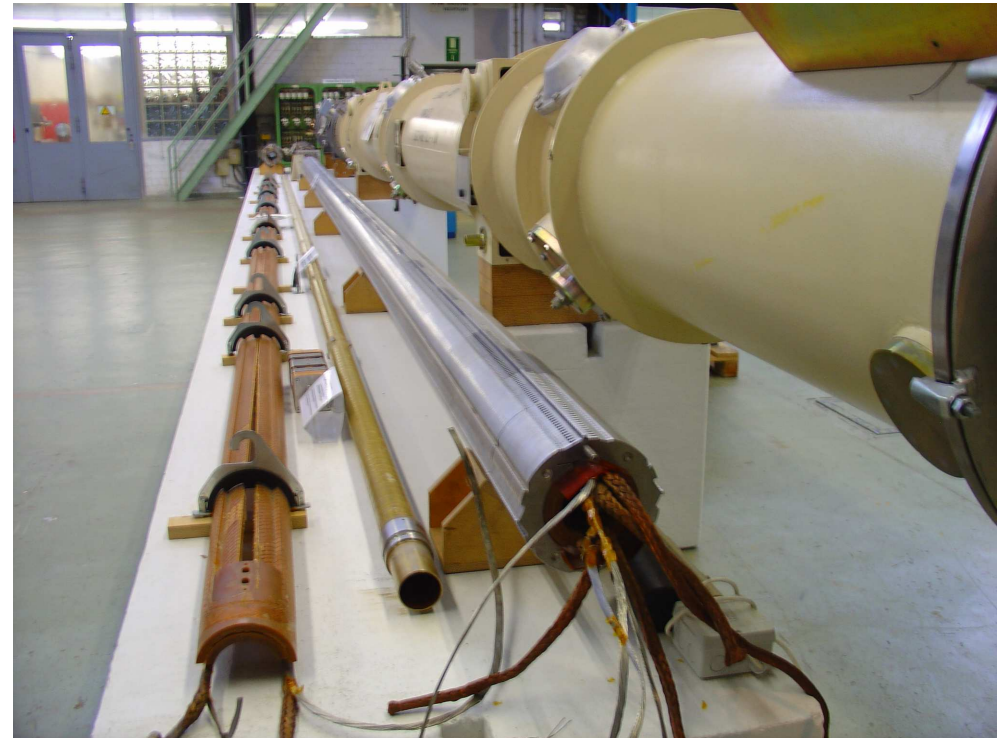

- **Conversion probability** of photon send along magnetic field:

$$P_{\gamma \leftrightarrow \phi} \approx \frac{1}{4} g^2 B^2 \ell^2 \left(\frac{\sin \left(\frac{m_\phi^2 \ell}{4\omega} \right)}{\frac{m_\phi^2 \ell}{4\omega}} \right)^2$$

$$\rightarrow \frac{1}{4} g^2 B^2 \ell^2$$

for $\omega \gg m_\phi^2 \ell / 2\pi$

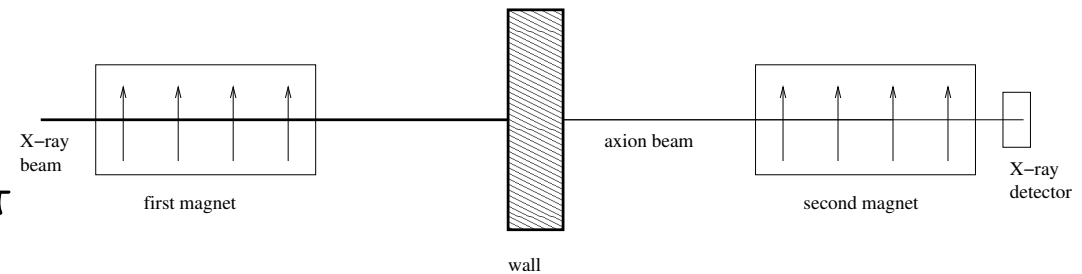

[Rabadan, AR, Sigurdson '05]

- ⇒ **Photon regeneration** optimal
- for large $B\ell \Rightarrow$ recycle dipole magnets from accelerators
 - for large $\omega \Rightarrow$ exploit VUV or X-ray free-electron lasers

- **Conversion probability** of photon send along magnetic field:

$$P_{\gamma \leftrightarrow \phi} \approx \frac{1}{4} g^2 B^2 \ell^2 \left(\frac{\sin\left(\frac{m_\phi^2 \ell}{4\omega}\right)}{\frac{m_\phi^2 \ell}{4\omega}} \right)^2$$

$$\rightarrow \frac{1}{4} g^2 B^2 \ell^2$$

for $\omega \gg m_\phi^2 \ell / 2\pi$

- ⇒ **Photon regeneration** optimal
- for large $B\ell \Rightarrow$ recycle dipole magnets from accelerators
 - for large $\omega \Rightarrow$ exploit VUV or X-ray free-electron lasers

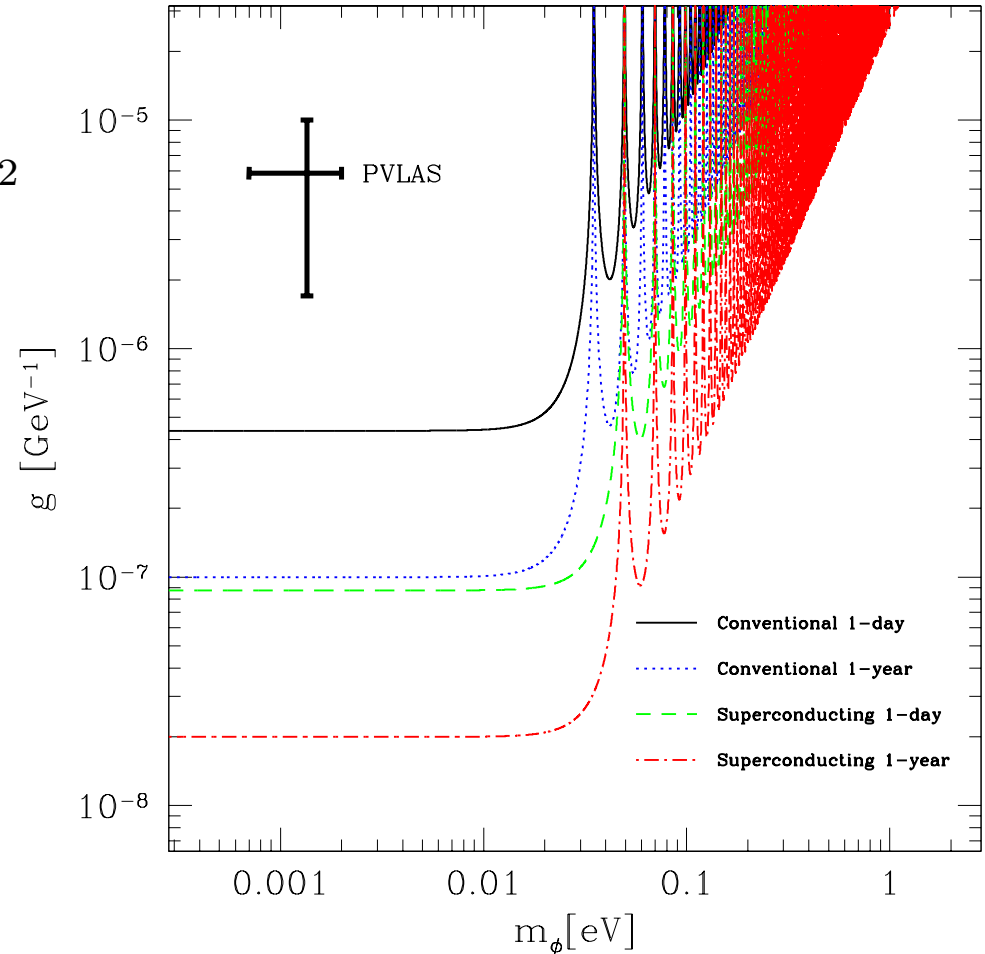

[Rabadan, AR, Sigurdson '05]

- **Powerful free-electron lasers (FEL)** already/soon available:

name?	ω [eV]	when?
VUV-FEL at TTF	10–200	2004
LCLS	10^4	2008
XFEL	200– 10^4	2011

TTF: TESLA Test Facility (DESY)

LCLS: Linac Coherent Light Source (SLAC)

SASE FEL:

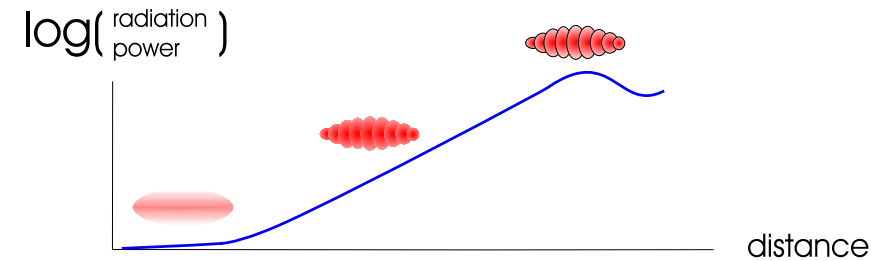
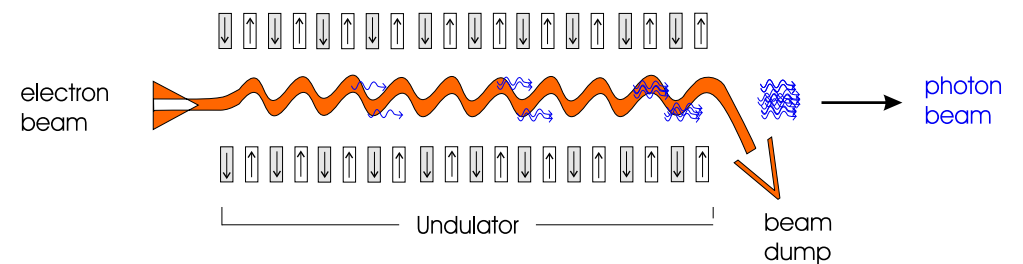

- **Powerful free-electron lasers (FEL)** already/soon available:

name?	ω [eV]	when?
VUV-FEL at TTF	10–200	2004
LCLS	10^4	2008
XFEL	200– 10^4	2011

TTF: TESLA Test Facility (DESY)

LCLS: Linac Coherent Light Source (SLAC)

VUV-FEL at TTF:

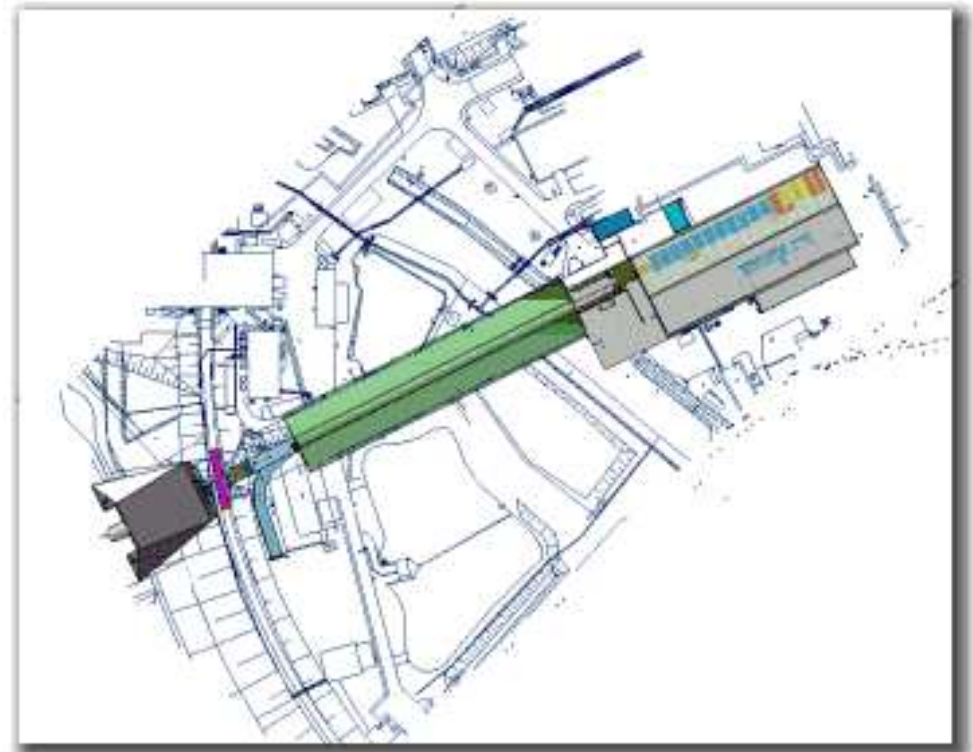

- **Powerful free-electron lasers (FEL)** already/soon available:

name?	ω [eV]	when?
VUV-FEL at TTF	10–200	2004
LCLS	10^4	2008
XFEL	200– 10^4	2011

TTF: TESLA Test Facility (DESY)

LCLS: Linac Coherent Light Source (SLAC)

VUV-FEL at TTF:



- Powerful free-electron lasers (FEL) already/soon available:

name?	ω [eV]	when?
VUV-FEL at TTF	10–200	2004
LCLS	10^4	2008
XFEL	200– 10^4	2011

TTF: TESLA Test Facility (DESY)

LCLS: Linac Coherent Light Source (SLAC)

- Axion Production at a Free-Electron Laser experiment may start this year

⇒ Study of feasibility underway ...

[Kötz, AR, Tschentscher]

A. Ringwald (DESY)

VUV-FEL experimental hall:

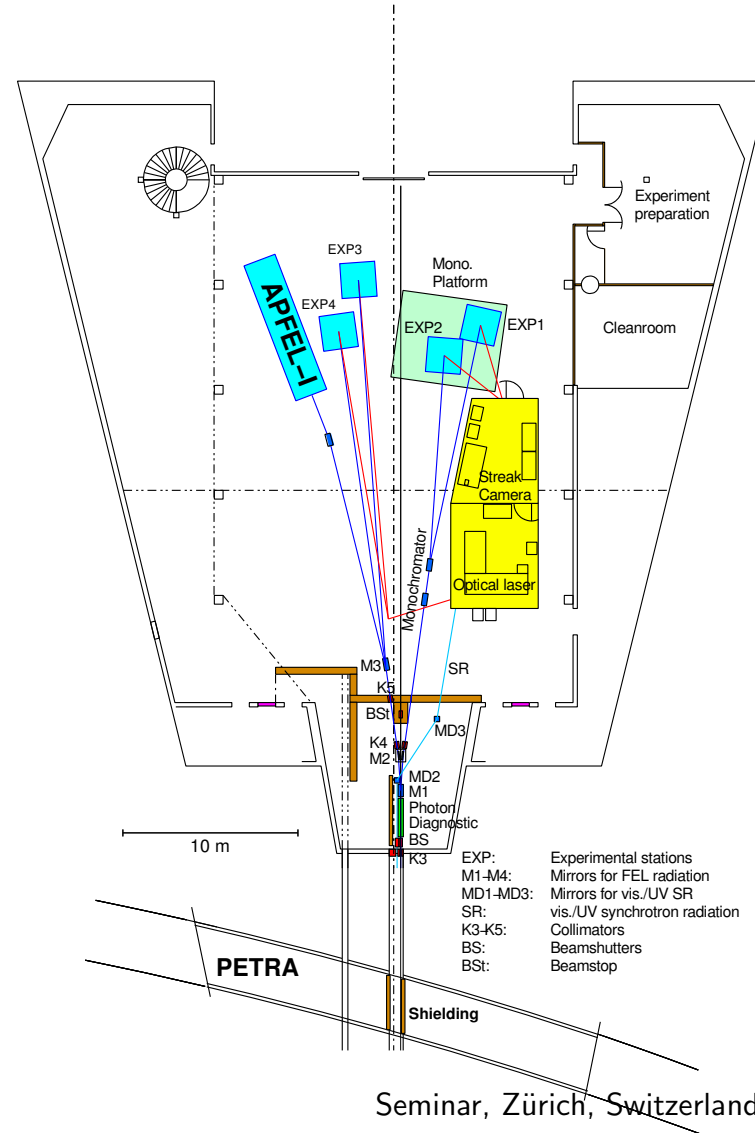

Feasibility study: [Kötz,AR,Tschentscher]

• **Benchmarks:**

– VUV-FEL:

$$\omega = 30 \text{ eV}, \dot{N}_0 = 10^{17} \text{ s}^{-1}$$

VUV-FEL parameters at TTF2:

	6.4 nm	30 nm	60 nm
ω [eV]	193	41.3	20.7
$\langle P \rangle$ [W]	40	27	23
\dot{N}_0 [1/s]	1.3×10^{18}	4.1×10^{18}	6.9×10^{18}
Δt [fs]	200	200	1000

[DESY-TESLA-FEL-2002-01]

Feasibility study: [Kötz,AR,Tschentscher]

● **Benchmarks:**

– VUV-FEL:

$$\omega = 30 \text{ eV}, \dot{N}_0 = 10^{17} \text{ s}^{-1}$$

– 5 dipole magnets “MB”:

$$B = 2.2 \text{ T}, \ell = 2.5 \text{ m}$$

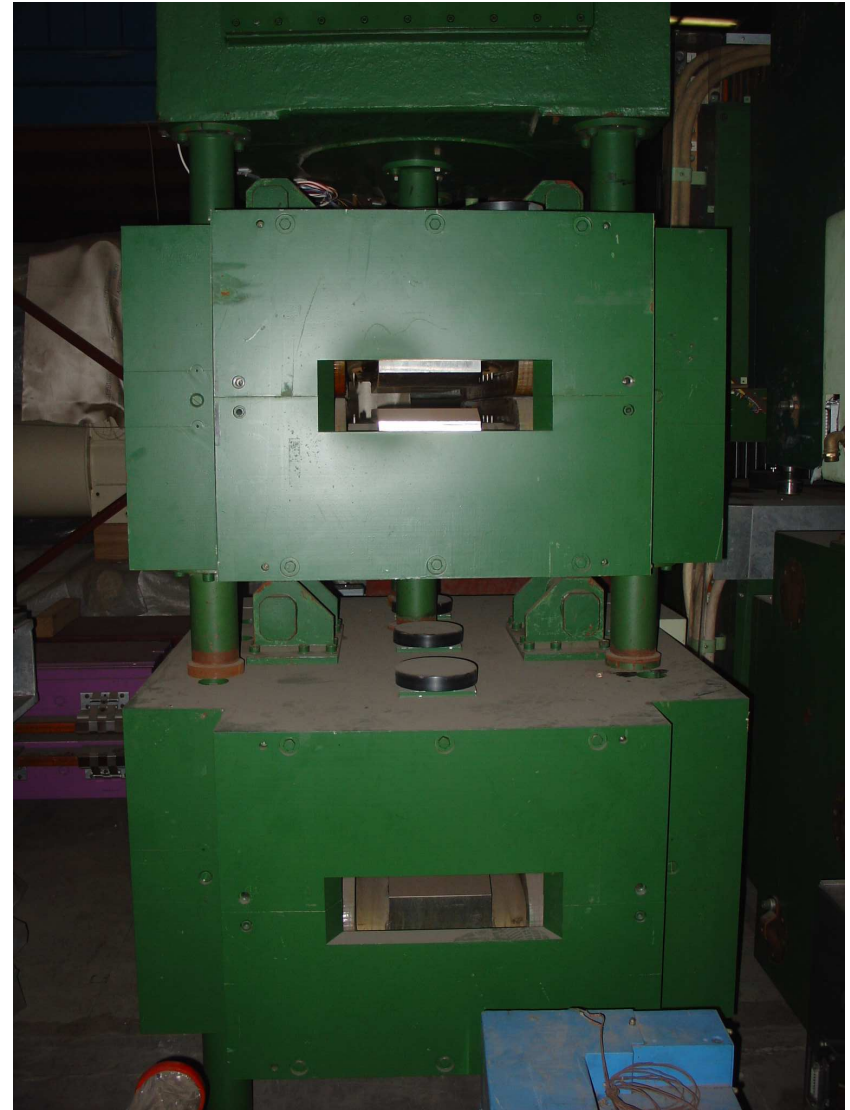

Feasibility study: [Kötz,AR,Tschentscher]

• Benchmarks:

- VUV-FEL:

$$\omega = 30 \text{ eV}, \dot{N}_0 = 10^{17} \text{ s}^{-1}$$

- 5 dipole magnets "MB":

$$B = 2.2 \text{ T}, \ell = 2.5 \text{ m}$$



Feasibility study: [Kötz,AR,Tschentscher]

● **Benchmarks:**

– VUV-FEL:

$$\omega = 30 \text{ eV}, \dot{N}_0 = 10^{17} \text{ s}^{-1}$$

– 5 dipole magnets “MB”:

$$B = 2.2 \text{ T}, \ell = 2.5 \text{ m}$$

Dipole magnet “MB”:

Freely available at DESY	12
Weight	7.5 t
Overall length between vacuum chamber flanges	1.52 m
Vacuum chamber height	0.108 m
Vacuum chamber width	0.303 m
Maximal current	1.5 kA
Field strength at maximal current	2.24 T
Power consumption at maximal current	400 kW
Integrated magnetic length	1.029 m
Necessary cooling water at max. current	146 l/min

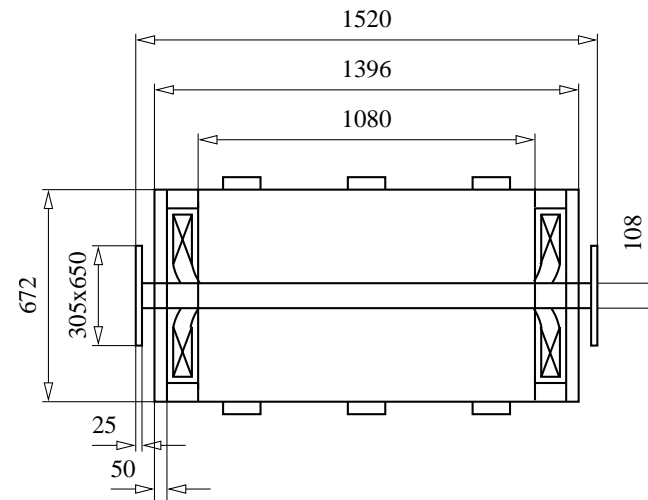

– Axion-Like Particle Generation . . . –

Feasibility study: [Kötz,AR,Tschentscher]

• **Benchmarks:**

– VUV-FEL:

$$\omega = 30 \text{ eV}, \dot{N}_0 = 10^{17} \text{ s}^{-1}$$

– 5 dipole magnets “MB”:

$$B = 2.2 \text{ T}, \ell = 2.5 \text{ m}$$

⇒ Flux of regenerated photons:

$$\dot{N}_f \approx 6 \times 10^{-6} \text{ s}^{-1} \left(\frac{\dot{N}_0}{10^{17} \text{ s}^{-1}} \right) F^2(q\ell) \left(\frac{g}{10^{-6} \text{ GeV}^{-1}} \right)^4 \left(\frac{B}{2.2 \text{ T}} \right)^4 \left(\frac{\ell}{2.5 \text{ m}} \right)^4$$

⇒ 20-30000 regenerated photons
from PVLAS ALP in $12 \times 12 \text{ h}$

A. Ringwald (DESY)

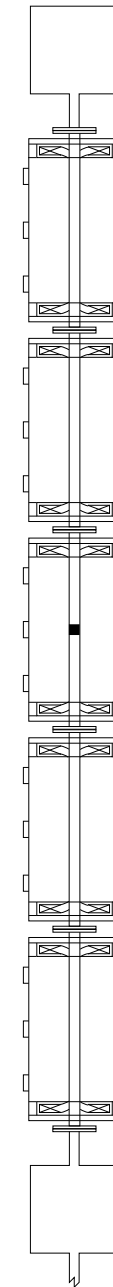

30

[Ahlers '05]

Seminar, Zürich, Switzerland

Feasibility study: [Kötz,AR,Tschentscher]

● **Benchmarks:**

– VUV-FEL:

$$\omega = 30 \text{ eV}, \dot{N}_0 = 10^{17} \text{ s}^{-1}$$

– 5 dipole magnets “MB”:

$$B = 2.2 \text{ T}, \ell = 2.5 \text{ m}$$

⇒ Flux of regenerated photons:

$$\dot{N}_f \approx 6 \times 10^{-6} \text{ s}^{-1} \left(\frac{\dot{N}_0}{10^{17} \text{ s}^{-1}} \right) F^2(q\ell) \left(\frac{g}{10^{-6} \text{ GeV}^{-1}} \right)^4 \left(\frac{B}{2.2 \text{ T}} \right)^4 \left(\frac{\ell}{2.5 \text{ m}} \right)^4$$

⇒ 20-30000 regenerated photons from PVLAS ALP in $12 \times 12 \text{ h}$

⇒ Determine mass by tuning ω

A. Ringwald (DESY)

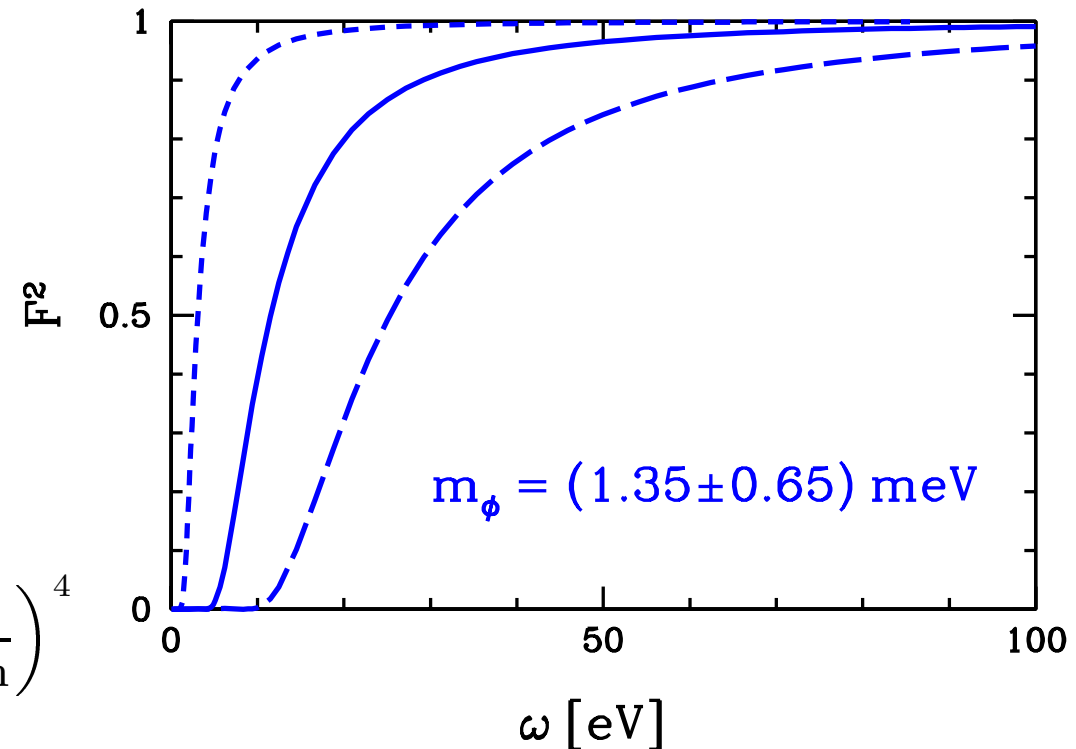

– Axion-Like Particle Generation . . . –

Feasibility study: [Kötz,AR,Tschentscher]

- Two photon detectors: entrance (N_0) and exit (N_f)

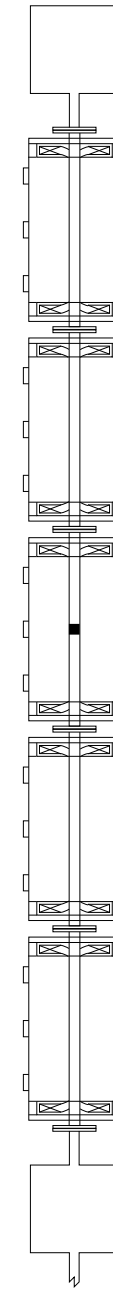

32

[Ahlers '05]

Feasibility study: [Kötz,AR,Tschentscher]

- Two photon detectors: entrance (N_0) and exit (N_f)
- Requirements on N_f detector: low noise and high efficiency, $\gtrsim 10\%$, e.g. Hamamatsu electron multiplier

Type	Aperture [mm]	Gain	Rise time [ns]
R5150	$\varnothing 8$	5×10^6	1.7
R2362	$\varnothing 20$	5×10^5	3.5
R474	8×6	1×10^6	9.3
R595	12×10	4×10^7	12
R596	12×10	1×10^6	10

[Hamamatsu Photonics '03 rev]

Spectral Response (Cu-BeO)

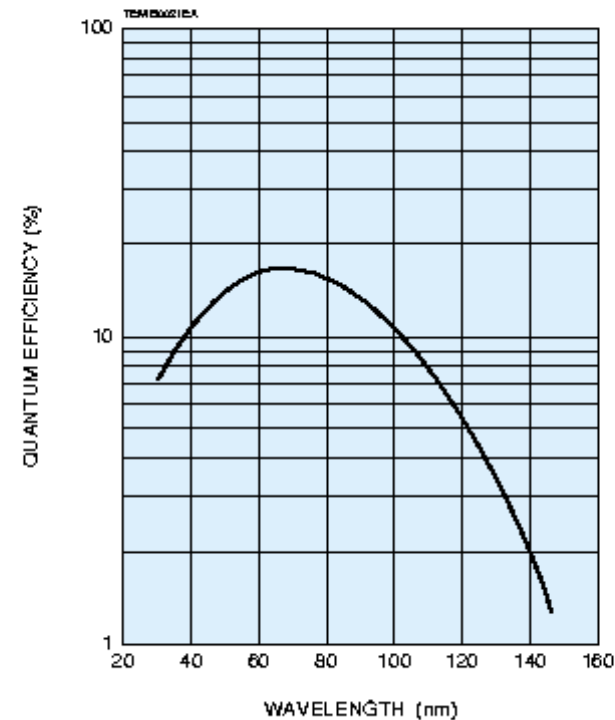

Feasibility study: [Kötz,AR,Tschentscher]

- Two photon detectors: entrance (N_0) and exit (N_f)
- Requirements on N_f detector: low noise and high efficiency, $\gtrsim 10\%$, e.g. Hamamatsu electron multiplier

⇒ Entire PVLAS parameter region probed within typical FEL run

- Timeline:
 - March 2006: Letter of Intent
 - End of 2006: Run experiment

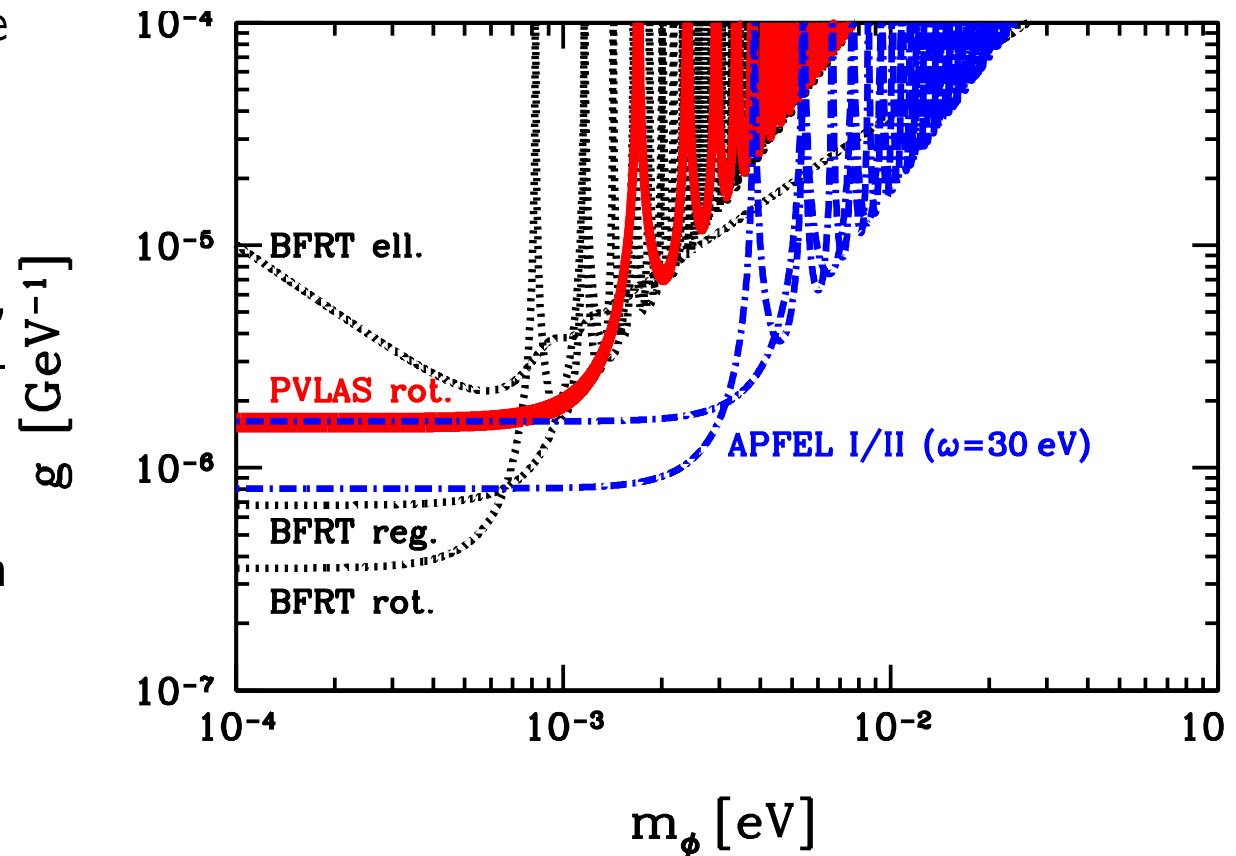

Expansion possibilities: [AR '03]

- Mid 2007: decommissioning of **HERA**

⇒ Photon regeneration with ≈ 400 superconducting dipole magnets ($B = 5 \text{ T}$, $\ell = 2000 \text{ m}$)

- sensitivity comparable to limits involving astrophysical considerations (HB stars; su)
- $B\ell$ still not large enough to be sensitive to the region where the axion qualifies as a cold dark matter candidate

- We need the **(V)LHC** magnets!

A. Ringwald (DESY)

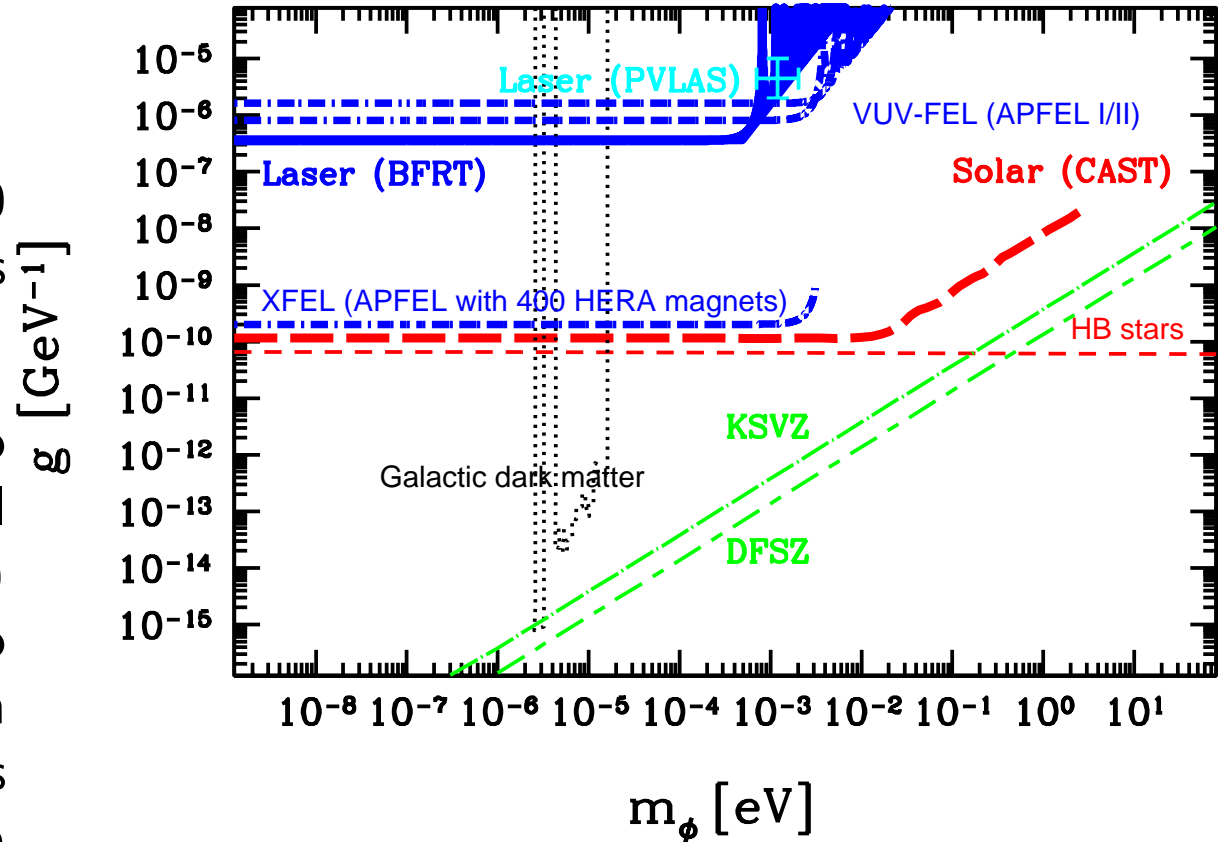

Seminar, Zürich, Switzerland

4. ALP Outlook

- Powerful VUV and X-ray FEL's, combined with recycled dipole magnets from accelerators, offer unique possibility for photon regeneration experiments
 - sensitivity towards larger m_ϕ as compared to optical lasers
 - larger detection efficiency
 - mass determination through tuning of ω
- PVLAS indication can be tested already next year with modest experiment
- Scheme can be expanded towards a large scale experiment